



EDI Implementation Documentation

Truck Shop Order

based on

ORDERS

Purchase order message

JAI EDIFACT D.03A

Version 1.04
Issue date 2011-01-04

Detailed guidelines of the order message within Volvo for Truck Shop

General

This document describes Volvo's application of the EDIFACT message for purchase order (ORDERS) and its relations to order response (ORDRSP).

The specification offers a detailed description of those data elements which will be used including recommended code listings.

The basis of the application is the EDIFACT message entitled ORDERS version D.03A

The frequency and scope of the ORDERS message are specific for the Volvo Truck Shop program.

Relations to other messages:

ORDERS message can ask supplier for a order response. Such response is performed by order response message ORDRSP.

Message usage:

It is important in all communication that buyer's and sellers prime references must be given. This to allow automatic processing in the order cycle, without manual intervention. That is also why free form text in a message is not recommended.

The purpose and the basic function of the message

The purpose of purchase order is to provide the seller/supplier with essential information involved in purchase of goods to be delivered to a dealership or to an other location defined by the dealer.

- * To buy parts to a Volvo aftermarket facility.

The message may contain the following information:

- * Who is the buyer.
- * Who is the seller.
- * Item number or description of goods.
- * Quantity of goods.
- * Where to deliver (consignee) or (Ultimate consignee)
- * Where to send Invoice.

Definitions

Name and Addresses

A Purchase order can have five NAD's indicating various kinds partners.

Buyer (NAD 3035 code = BY)

BY tells who the buyer is.

Seller (NAD 3035 code = SE)

SE tells who the seller is.

Invoicee (NAD 3035 code = IV)

IV tells where to send invoice.

Consignee (NAD 3035 code = CN)

CN tells where to send goods.

Ultimate Consignee (NAD 3035 code = UC)

UC tells where goods finally will end up if CN is not the final goods receiver.

The goods must be shipped to the address given in NAD UC, unless the supplier is excluded from shipping to alternative addresses.

Status codes (St)

EDIFACT standard definition

M = Mandatory

C = Conditional

Volvo standard definition

R = Required

D = Dependent

O = Optional

N = Not used

Revisions

Date	Issued by	Revision	Remarks
2005-09-30	Volvo IT 9642	1.03	First published revision
2011-01-04	Volvo IT 9544	1.04	The following minor modifications have been introduced: <ul style="list-style-type: none">• New segment SG4/FTX+ACB 4451 has been introduced.• Conditions for occurrence of certain elements have been changed• Editorial improvements of explanations and comments• Conditions for occurrence of certain elements have been changed

TRUCK SHOP ORDER

UN/EDIFACT Message: Structure / Table of contents

Counter	No.	Tag	St	Rep	Content
	0010	01 UNH	M	1	Message header
	0020	02 BGM	M	1	Beginning of message
	0030	03 DTM	M	1	Document Date/Time
	0070	04 FTX	D	1	Free text
┌	0090	SG1	R	9999	Original purchase order
└	0100	05 RFF	M	1	Reference
┌	0090	SG1	R	9999	Customer reference number
└	0100	06 RFF	D	1	Reference
┌	0120	SG2	R	1	Buyer
└	0130	07 NAD	M	1	Buyer
┌	0160	SG3	R	1	Buyer's reference number
└	0170	08 RFF	M	1	Buyer's reference number
┌	0120	SG2	R	1	Invoicee
└	0130	09 NAD	M	1	Invoicee
┌	0160	SG3	R	1	Invoicee's reference number(s)
└	0170	10 RFF	M	1	Invoicee's reference number(s)
┌	0120	SG2	R	1	Seller
└	0130	11 NAD	M	1	Seller
┌	0160	SG3	R	1	Seller's reference number(s)
└	0170	12 RFF	M	1	Sellers's reference number(s)
┌	0120	SG2	R	1	Consignee
└	0130	13 NAD	M	1	Consignee
┌	0120	SG2	D	1	Ultimate Consignee
└	0130	14 NAD	M	1	Ultimate Consignee
┌	0290	SG7	D	1	Order currency
└	0300	15 CUX	M	1	Currencies
┌	1030	SG28	R	2000	Line item section
└	1040	16 LIN	M	1	Line item
└	1050	17 PIA	D	1	Additional article identifier
└	1060	18 IMD	R	1	Item description
└	1080	19 QTY	R	1	Quantity
┌	1320	SG32	D	1	PRI
└	1330	20 PRI	R	1	Price details
┌	1380	SG33	R	1	RFF
└	1390	21 RFF	M	1	Vips order line number

TRUCK SHOP ORDER

Counter	No. Tag	St	Rep	Content
2330	22 UNS	M	1	Section control
2400	23 UNT	M	1	Message trailer

TRUCK SHOP ORDER

UN/EDIFACT Message: Branching diagramm of used segments and segment groups

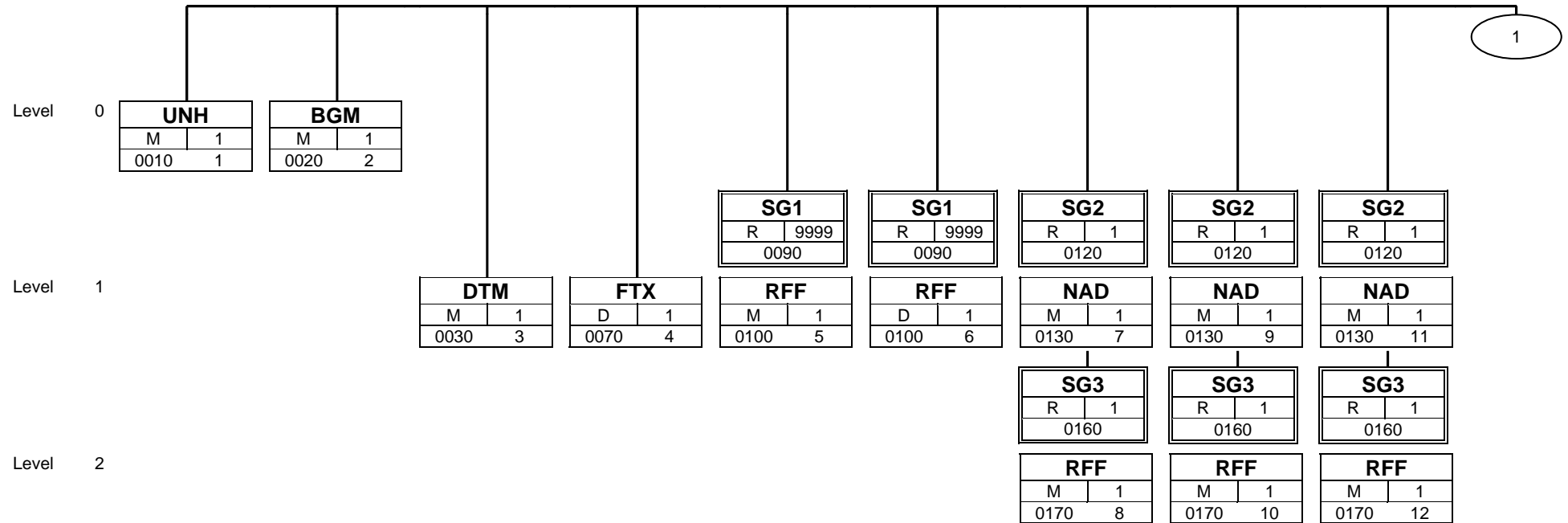

Truck Shop Order based on ORDERS / JAI EDIFACT D.03A

Document Number
Layout: (C) GEFEG EDIFIX (R)

Issue: 1.04 Dated: 2011-01-04

TRUCK SHOP ORDER

UN/EDIFACT Message: Branching diagram of used segments and segment groups

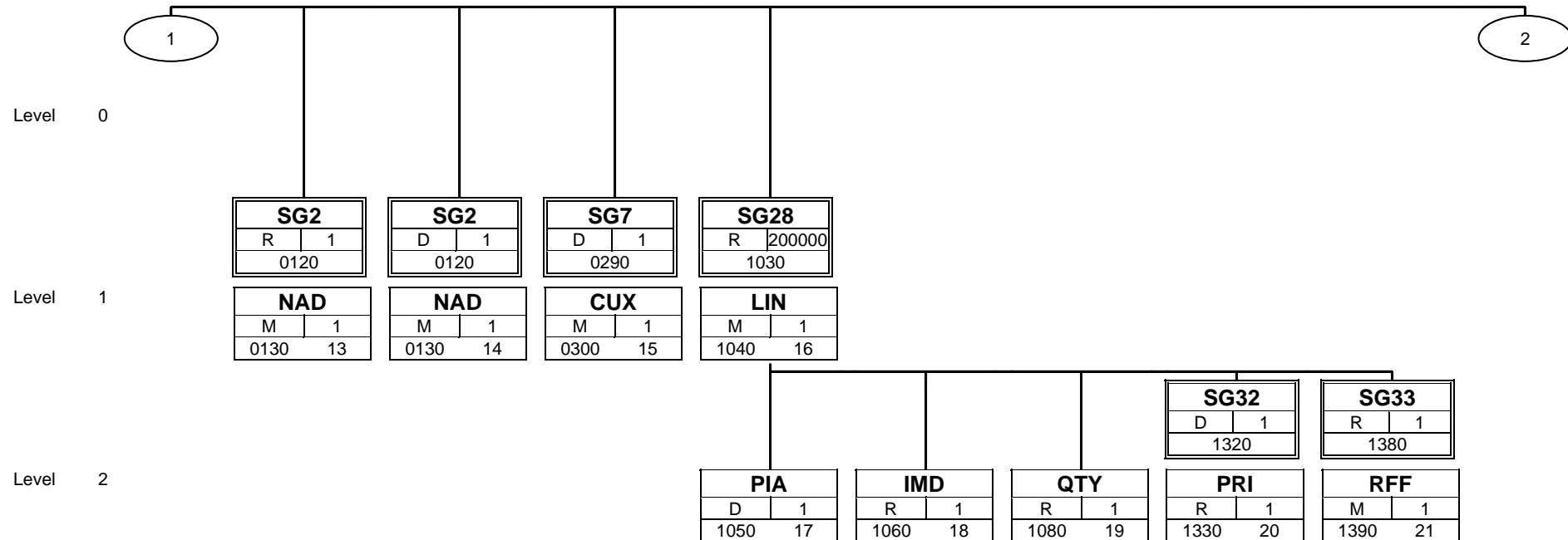

Truck Shop Order based on ORDERS / JAI EDIFACT D.03A

Document Number
Layout: (C) GEFEG EDIFIX (R)

Issue: 1.04 Dated: 2011-01-04

TRUCK SHOP ORDER

UN/EDIFACT Message: Branching diagram of used segments and segment groups

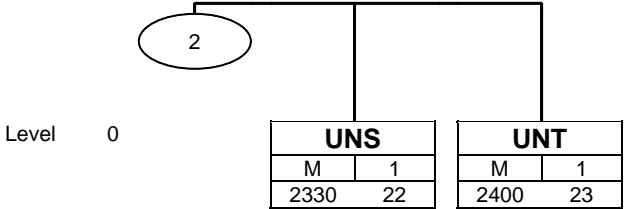

TRUCK SHOP ORDER

UN/EDIFACT Message: Segment details

Segment: **UNH** Seq. No.: 1 Level: 0 **Message header**
Status: M Max. Occ.: 1
Counter: 0010

Name: Message header

Description of segment:

UN/EDIFACT		Implementation		
	Name	St Format	St Format	Use / Remarks
UNH				
0062	Message reference number	M an..14	M an..14	
S009	Message identifier	M	M	
0065	Message type	M an..6	M an..6	ORDERS
0052	Message version number	M an..3	M an..3	D
0054	Message release number	M an..3	M an..3	03A
0051	Controlling agency	M an..2	M an..2	
0057	Association assigned code	C an..6	N	UN = UN/CEFACT not used
0068	Common access reference	C an..35	R an..35	TSE = Truck Shop Europe
S010	Status of the transfer	C	N	not used
0070	Sequence of transfers	M n..2	N	not used
0073	First and last transfer	C a1	N	not used

Remark:

Example:

UNH+10045+ORDERS:D:03A:UN+TSE'

TRUCK SHOP ORDER

UN/EDIFACT Message: Segment details

Segment: **BGM** Seq. No.: 2 Level: 0 Beginning of message
 Status: M Max. Occ.: 1
 Counter: 0020

Name: Beginning of message

Description of segment:

UN/EDIFACT			Implementation	
	Name	St Format	St Format	Use / Remarks
BGM				
C002	Document/message name	C	C	
1001	Document name code	C an..3	R an..3	
1131	Code list identification code	C an..17	N	not used
3055	Code list responsible agency code	C an..3	N	not used
1000	Document name	C an..35	N	not used
C106	Document/message identification	C	R	
1004	Document identifier	C an..35	R an..35	Order number
1056	Version identifier	C an..9	N	not used
1060	Revision identifier	C an..6	N	not used
1225	Message function code	C an..3	R an..3	
4343	Response type code	C an..3	R an..3	<p>9 = Original</p> <p>When AC an ORDRSP is expected for each ORDER When US an ORDRSP is expected when there is any kind of deviation from normal as for example: Back order, Price error, Substituted part, etc.</p> <p>AC = Acknowledge - with detail and change NA = No acknowledgement needed US = Acknowledgement when error</p>

Remark:

Example:

BGM+220+296246123243+9+AC'

TRUCK SHOP ORDER

UN/EDIFACT Message: Segment details

Segment: **DTM** Seq. No.: 3 Level: 1 Date/time/period
Status: M Max. Occ.: 1
Counter: 0030

Name: Document Date/Time

Description of segment:

UN/EDIFACT		Implementation		
	Name	St Format	St Format	Use / Remarks
DTM				
C507	Date/time/period	M	M	
2005	Date or time or period function code qualifier	M an..3	M an..3	
2380	Date or time or period text	C an..35	R an..35	137 = Document/message date/time Date and time as the code below indicate
2379	Date or time or period format code	C an..3	R an..3	102 = CCYYMMDD

Remark:

Example:

DTM+137:20050430:102'

TRUCK SHOP ORDER

UN/EDIFACT Message: Segment details

Segment: **FTX** Seq. No.: 4 Level: 1 **Free text**
Status: D Max. Occ.: 1
Counter: 0070

Name: Free text

Description of segment:

UN/EDIFACT		Implementation		
	Name	St Format	St Format	Use / Remarks
FTX				
4451	Text subject code qualifier	M an..3	M an..3	ACB = Additional information
4453	Free text function code	C an..3	N	not used
C107	Text reference	C	N	not used
4441	Free text description code	M an..17	N	not used
1131	Code list identification code	C an..17	N	not used
3055	Code list responsible agency code	C an..3	N	not used
C108	Text literal	C	M	
4440	Free text	M an..512	M 70	A line of plain, non-structured text information.
4440	Free text	C an..512	N	not used
4440	Free text	C an..512	N	not used
4440	Free text	C an..512	N	not used
4440	Free text	C an..512	N	not used
3453	Language name code	C an..3	N	not used
4447	Free text format code	C an..3	N	not used

Remark:
Used after agreement.

Example:
`'FTX+ACB+++Additional information'`

TRUCK SHOP ORDER

UN/EDIFACT Message: Segment details

Group: **SG1** Status: R Max. Occ.: 9999 Original purchase order

Segment: **RFF** Seq. No.: 5 Level: 1 **Reference**
Status: M Max. Occ.: 1
Counter: 0100

Name: Reference

Description of segment:

UN/EDIFACT			Implementation	
	Name	St Format	St Format	Use / Remarks
RFF				
C506	Reference	M	M	
1153	Reference code qualifier	M an..3	R an..3	
1154	Reference identifier	C an..70	R an..70	OP = Original purchase order Customer order number.
1156	Document line identifier	C an..6	N	not used
4000	Reference version identifier	C an..35	N	not used
1060	Revision identifier	C an..6	N	not used

Remark:

Customer order number created by Truck Shop and provided to Dealer as reference.

Example:

RFF+OP:DK-000001191002'

TRUCK SHOP ORDER

UN/EDIFACT Message: Segment details

Group: **SG1** Status: R Max. Occ.: 9999 Customer reference number

Segment: **RFF** Seq. No.: 6 Level: 1 **Reference**
Status: D Max. Occ.: 1
Counter: 0100

Name: Reference

Description of segment:

UN/EDIFACT			Implementation	
	Name	St Format	St Format	Use / Remarks
RFF				
C506	Reference	M	M	
1153	Reference code qualifier	M an..3	R an..3	
1154	Reference identifier	C an..70	R an..70	CR = Customer reference number Customer reference number
1156	Document line identifier	C an..6	N	not used
4000	Reference version identifier	C an..35	N	not used
1060	Revision identifier	C an..6	N	not used

Remark:

Customer reference number provided by the Dealer as reference.

Example:

RFF+CR:1011176105'

TRUCK SHOP ORDER

UN/EDIFACT Message: Segment details

Group: **SG2** Status: R Max. Occ.: 1 Buyer

Segment: **NAD** Seq. No.: 7 Level: 1 **Name and address**
 Status: M Max. Occ.: 1
 Counter: 0130

Name: **Buyer**

Description of segment:

UN/EDIFACT			Implementation	
	Name	St Format	St Format	Use / Remarks
NAD				
3035	Party function code qualifier	M an..3	M an..3	BY = Buyer
C082	Party identification details	C	R	
3039	Party identifier	M an..35	M an..35	Buyer's Identification Number (Parma)
1131	Code list identification code	C an..17	N	not used
3055	Code list responsible agency code	C an..3	R an..3	
				92 = Assigned by buyer or buyer's agent
C058	Name and address	C	N	not used
3124	Name and address description	M an..35	N	not used
3124	Name and address description	C an..35	N	not used
3124	Name and address description	C an..35	N	not used
3124	Name and address description	C an..35	N	not used
3124	Name and address description	C an..35	N	not used
C080	Party name	C	R	Required in the new EU Invoice directive
3036	Party name	M an..35	M an..35	Buyer's Name
3036	Party name	C an..35	D an..35	see 3036 # 1
3036	Party name	C an..35	N	not used
3036	Party name	C an..35	N	not used
3036	Party name	C an..35	N	not used
3045	Party name format code	C an..3	N	not used
C059	Street	C	D	Required in the new EU Invoice directive
3042	Street and number or post office box identifier	M an..35	M an..35	Buyer's Street
3042	Street and number or post office box identifier	C an..35	D an..35	see 3042 # 1
3042	Street and number or post office box identifier	C an..35	N	not used
3042	Street and number or post office box identifier	C an..35	N	not used
3164	City name	C an..35	R an..35	Required in the new EU Invoice directive Buyer's City
C819	Country sub-entity details	C	D	
3229	Country sub-entity name code	C an..9	D an..9	
1131	Code list identification code	C an..17	N	not used
3055	Code list responsible agency code	C an..3	N	not used
3228	Country sub-entity name	C an..70	N	not used
3251	Postal identification code	C an..17	R an..17	Buyer's Post code

TRUCK SHOP ORDER

UN/EDIFACT Message: Segment details

UN/EDIFACT			Implementation	
	Name	St Format	St Format	Use / Remarks
3207	Country name code	C an..3	R an..2	Buyer's Country code Provides the country part of an adress using a code. Use ISO 3166 two alpha code.

Remark:

Example:

NAD+BY+1001::92++VOLVO TRUCK CORPORATION AB++GOTHENBURG++405 08+SE'

TRUCK SHOP ORDER

UN/EDIFACT Message: Segment details

Group: **SG3** Status: R Max. Occ.: 1 Buyer's reference number

Segment: **RFF** Seq. No.: 8 Level: 2 **Reference**
Status: M Max. Occ.: 1
Counter: 0170

Name: Buyer's reference number

Description of segment:

UN/EDIFACT			Implementation	
	Name	St Format	St Format	Use / Remarks
RFF				
C506	Reference	M	M	
1153	Reference code qualifier	M an..3	M an..3	VA: Required in the new EU Invoice directive VA = VAT registration number
1154	Reference identifier	C an..70	R an..17	Buyer's VAT number
1156	Document line identifier	C an..6	N	not used
4000	Reference version identifier	C an..35	N	not used
1060	Revision identifier	C an..6	N	not used

Remark:

Example:

RFF+VA:SE556013970001'

TRUCK SHOP ORDER

UN/EDIFACT Message: Segment details

Group: **SG2** Status: R Max. Occ.: 1 Invoicee

Segment: **NAD** Seq. No.: 9 Level: 1 **Name and address**
 Status: M Max. Occ.: 1
 Counter: 0130

Name: **Invoicee**

Description of segment:

UN/EDIFACT			Implementation	
	Name	St Format	St Format	Use / Remarks
NAD				
3035	Party function code qualifier	M an..3	M an..3	IV = Invoicee
C082	Party identification details	C	R	
3039	Party identifier	M an..35	M an..35	Invoicee Identification Number (Parma)
1131	Code list identification code	C an..17	N	not used
3055	Code list responsible agency code	C an..3	R an..3	
				92 = Assigned by buyer or buyer's agent
C058	Name and address	C	N	not used
3124	Name and address description	M an..35	N	not used
3124	Name and address description	C an..35	N	not used
3124	Name and address description	C an..35	N	not used
3124	Name and address description	C an..35	N	not used
3124	Name and address description	C an..35	N	not used
C080	Party name	C	R	Required in the new EU Invoice directive
3036	Party name	M an..35	M an..35	Invoicee's Name
3036	Party name	C an..35	D an..35	see 3036 # 1
3036	Party name	C an..35	N	not used
3036	Party name	C an..35	N	not used
3036	Party name	C an..35	N	not used
3045	Party name format code	C an..3	N	not used
C059	Street	C	D	Required in the new EU Invoice directive
3042	Street and number or post office box identifier	M an..35	M an..35	Invoicee Street
3042	Street and number or post office box identifier	C an..35	D an..35	see 3042 # 1
3042	Street and number or post office box identifier	C an..35	N	not used
3042	Street and number or post office box identifier	C an..35	N	not used
3164	City name	C an..35	R an..35	Invoicee's City Name
C819	Country sub-entity details	C	D	
3229	Country sub-entity name code	C an..9	D an..9	
1131	Code list identification code	C an..17	N	not used
3055	Code list responsible agency code	C an..3	N	not used
3228	Country sub-entity name	C an..70	N	not used
3251	Postal identification code	C an..17	R an..17	Invoicee Post code

TRUCK SHOP ORDER

UN/EDIFACT Message: Segment details

UN/EDIFACT			Implementation	
	Name	St Format	St Format	Use / Remarks
3207	Country name code	C an..3	R an..2	Invoicee Country code Provides the country part of an adress using a code. Use ISO 3166 two alpha code.

Remark:

Example:

NAD+IV+296246:::92++VOLVO LASTVOGNE DANMARK A/S+RINGAGER 6:POSTBOX 176+BRÖNDBY++2505+DK'

TRUCK SHOP ORDER

UN/EDIFACT Message: Segment details

Group: **SG3** Status: R Max. Occ.: 1 Invoicee's reference number(s)

Segment: **RFF** Seq. No.: 10 Level: 2 **Reference**
Status: M Max. Occ.: 1
Counter: 0170

Name: Invoicee's reference number(s)

Description of segment:

UN/EDIFACT			Implementation	
	Name	St Format	St Format	Use / Remarks
RFF				
C506	Reference	M	M	
1153	Reference code qualifier	M an..3	M an..3	VA: Required in the new EU Invoice directive VA = VAT registration number
1154	Reference identifier	C an..70	R an..17	Invoicee's VAT number
1156	Document line identifier	C an..6	N	not used
4000	Reference version identifier	C an..35	N	not used
1060	Revision identifier	C an..6	N	not used

Remark:

Example:

RFF+VA:DK26178509'

TRUCK SHOP ORDER

UN/EDIFACT Message: Segment details

Group: **SG2** Status: R Max. Occ.: 1 Seller

Segment: **NAD** Seq. No.: 11 Level: 1 Name and address
 Status: M Max. Occ.: 1
 Counter: 0130

Name: Seller

Description of segment:

UN/EDIFACT			Implementation	
	Name	St Format	St Format	Use / Remarks
NAD				
3035	Party function code qualifier	M an..3	M an..3	SE - party selling merchandise to a buyer. SE = Seller
C082	Party identification details	C	R	
3039	Party identifier	M an..35	M an..35	Required in the new EU Invoice directive
1131	Code list identification code	C an..17	N	not used
3055	Code list responsible agency code	C an..3	R an..3	
				92 = Assigned by buyer or buyer's agent
C058	Name and address	C	N	not used
3124	Name and address description	M an..35	N	not used
3124	Name and address description	C an..35	N	not used
3124	Name and address description	C an..35	N	not used
3124	Name and address description	C an..35	N	not used
3124	Name and address description	C an..35	N	not used
C080	Party name	C	R	Required in the new EU Invoice directive
3036	Party name	M an..35	M an..35	
3036	Party name	C an..35	D an..35	see 3036 # 1
3036	Party name	C an..35	N	not used
3036	Party name	C an..35	N	not used
3036	Party name	C an..35	N	not used
3045	Party name format code	C an..3	N	not used
C059	Street	C	D	
3042	Street and number or post office box identifier	M an..35	M an..35	Seller's Street
3042	Street and number or post office box identifier	C an..35	D an..35	see 3042 # 1
3042	Street and number or post office box identifier	C an..35	N	not used
3042	Street and number or post office box identifier	C an..35	N	not used
3164	City name	C an..35	R an..35	Seller's City Name
C819	Country sub-entity details	C	D	
3229	Country sub-entity name code	C an..9	D an..9	
1131	Code list identification code	C an..17	N	not used
3055	Code list responsible agency code	C an..3	N	not used
3228	Country sub-entity name	C an..70	N	not used
3251	Postal identification code	C an..17	R an..17	Seller's Postcode

TRUCK SHOP ORDER

UN/EDIFACT Message: Segment details

UN/EDIFACT			Implementation	
	Name	St Format	St Format	Use / Remarks
3207	Country name code	C an..3	R an..3	Seller's Country code Provides the country part of an adress using a code. Use ISO 3166 two alpha code.

Remark:

Example:

NAD+SE+121212::92++DANSK SELLER A/S+ARMAGER STRANDVEJ 1002+COPENHAGEN++2300+DK'

TRUCK SHOP ORDER

UN/EDIFACT Message: Segment details

Group: **SG3** Status: R Max. Occ.: 1 Seller's reference number(s)
Required in the new EU Invoice directive

Segment: **RFF** Seq. No.: 12 Level: 2 **Reference**
Status: M Max. Occ.: 1
Counter: 0170

Name: Sellers's reference number(s)

Description of segment:

UN/EDIFACT			Implementation	
	Name	St Format	St Format	Use / Remarks
RFF				
C506	Reference	M	M	VA: Required in the new EU Invoice directive
1153	Reference code qualifier	M an..3	M an..3	
1154	Reference identifier	C an..70	R an..17	VA = VAT registration number Sellers's VAT number
1156	Document line identifier	C an..6	N	not used
4000	Reference version identifier	C an..35	N	not used
1060	Revision identifier	C an..6	N	not used

Remark:

Example:

RFF+VA:DK99999999'

TRUCK SHOP ORDER

UN/EDIFACT Message: Segment details

Group: **SG2** Status: R Max. Occ.: 1 Consignee

Segment: **NAD** Seq. No.: 13 Level: 1 **Name and address**
 Status: M Max. Occ.: 1
 Counter: 0130

Name: **Consignee**

Description of segment:

UN/EDIFACT			Implementation	
	Name	St Format	St Format	Use / Remarks
NAD				
3035	Party function code qualifier	M an..3	M an..3	CN = Consignee
C082	Party identification details	C	M	
3039	Party identifier	M an..35	M an..35	
1131	Code list identification code	C an..17	N	not used
3055	Code list responsible agency code	C an..3	R an..3	
				92 = Assigned by buyer or buyer's agent
C058	Name and address	C	N	not used
3124	Name and address description	M an..35	N	not used
3124	Name and address description	C an..35	N	not used
3124	Name and address description	C an..35	N	not used
3124	Name and address description	C an..35	N	not used
3124	Name and address description	C an..35	N	not used
C080	Party name	C	R	
3036	Party name	M an..35	M an..35	Consignee Name
3036	Party name	C an..35	D an..35	see 3036 # 1
3036	Party name	C an..35	N	not used
3036	Party name	C an..35	N	not used
3036	Party name	C an..35	N	not used
3045	Party name format code	C an..3	N	not used
C059	Street	C	D	
3042	Street and number or post office box identifier	M an..35	M an..35	Consignee Street
3042	Street and number or post office box identifier	C an..35	D an..35	see 3042 # 1
3042	Street and number or post office box identifier	C an..35	N	not used
3042	Street and number or post office box identifier	C an..35	N	not used
3164	City name	C an..35	R an..35	Consignee City Name
C819	Country sub-entity details	C	D	
3229	Country sub-entity name code	C an..9	D an..9	
1131	Code list identification code	C an..17	N	not used
3055	Code list responsible agency code	C an..3	N	not used
3228	Country sub-entity name	C an..70	N	not used
3251	Postal identification code	C an..17	R an..17	Consignee Postcode

TRUCK SHOP ORDER

UN/EDIFACT Message: Segment details

UN/EDIFACT			Implementation	
	Name	St Format	St Format	Use / Remarks
3207	Country name code	C an..3	O an..2	Consignee Country code Provides the country part of an adress using a code. Use ISO 3166 two alpha code.

Remark:

Example:

NAD+CN+DK997:::92++AUTOHUSET VESTERGAARD A/S+FÅLDESVEJ 13+GRINDSTED++7200+DK'

TRUCK SHOP ORDER

UN/EDIFACT Message: Segment details

Group: **SG2** Status: D Max. Occ.: 1 Ultimate Consignee
 Is only to be used when the Ship To address is different than the formal consignee

Segment: **NAD** Seq. No.: 14 Level: 1 **Name and address**
 Status: M Max. Occ.: 1
 Counter: 0130

Name: **Ultimate Consignee**

Description of segment:

UN/EDIFACT			Implementation	
	Name	St Format	St Format	Use / Remarks
NAD				
3035	Party function code qualifier	M an..3	M an..3	UC = Ultimate consignee
C082	Party identification details	C	R	
3039	Party identifier	M an..35	M an..35	Required in the new EU Invoice directive
1131	Code list identification code	C an..17	N	not used
3055	Code list responsible agency code	C an..3	R an..3	
				92 = Assigned by buyer or buyer's agent
C058	Name and address	C	N	not used
3124	Name and address description	M an..35	N	not used
3124	Name and address description	C an..35	N	not used
3124	Name and address description	C an..35	N	not used
3124	Name and address description	C an..35	N	not used
3124	Name and address description	C an..35	N	not used
C080	Party name	C	R	
3036	Party name	M an..35	M an..35	Ultimate Consignee Name
3036	Party name	C an..35	D an..35	see 3036 1#
3036	Party name	C an..35	N	not used
3036	Party name	C an..35	N	not used
3036	Party name	C an..35	N	not used
3045	Party name format code	C an..3	N	not used
C059	Street	C	R	
3042	Street and number or post office box identifier	M an..35	M an..35	Ultimate Consignee Street
3042	Street and number or post office box identifier	C an..35	D an..35	see 3042 1#
3042	Street and number or post office box identifier	C an..35	N	not used
3042	Street and number or post office box identifier	C an..35	N	not used
3164	City name	C an..35	R an..35	Ultimate Consignee City Name
C819	Country sub-entity details	C	D	
3229	Country sub-entity name code	C an..9	R an..9	
1131	Code list identification code	C an..17	N	not used
3055	Code list responsible agency code	C an..3	N	not used
3228	Country sub-entity name	C an..70	N	not used
3251	Postal identification code	C an..17	R an..17	Ultimate Consignee Postcode

TRUCK SHOP ORDER

UN/EDIFACT Message: Segment details

UN/EDIFACT			Implementation	
	Name	St Format	St Format	Use / Remarks
3207	Country name code	C an..3	R an..2	Ultimate Consignee Country code Provides the country part of an adress using a code. Use ISO 3166 two alpha code.

Remark:

Example:

NAD+UC+++BENNY`S CONTAINER TRANSPORT+TÅRNVEJ 55+GRINDSTED++7200+DK'

TRUCK SHOP ORDER

UN/EDIFACT Message: Segment details

Group: **SG7** Status: D Max. Occ.: 1 Order currency

Segment: **CUX** Seq. No.: 15 Level: 1 **Currencies**
 Status: M Max. Occ.: 1
 Counter: 0300

Name: Currencies

Description of segment:

UN/EDIFACT			Implementation	
	Name	St Format	St Format	Use / Remarks
CUX				
C504	Currency details	C	R	
6347	Currency usage code qualifier	M an..3	M an..3	
6345	Currency identification code	C an..3	R an..3	2 = Reference currency
6343	Currency type code qualifier	C an..3	R an..3	Order currency ISO 4217 three alpha code
6348	Currency rate	C n..4	N	9 = Order currency not used
C504	Currency details	C	N	not used
6347	Currency usage code qualifier	M an..3	N	not used
6345	Currency identification code	C an..3	N	not used
6343	Currency type code qualifier	C an..3	N	not used
6348	Currency rate	C n..4	N	not used
5402	Currency exchange rate	C n..12	N	not used
6341	Exchange rate currency market identifier	C an..3	N	not used

Remark:

Example:

CUX+2 : DKK : 9 '

TRUCK SHOP ORDER

UN/EDIFACT Message: Segment details

Group: **SG28** Status: R Max. Occ.: 200000 Line item section

Segment: **LIN** Seq. No.: 16 Level: 1 **Line item**
 Status: M Max. Occ.: 1
 Counter: 1040

Name: **Line item**

Description of segment:

UN/EDIFACT			Implementation	
	Name	St Format	St Format	Use / Remarks
LIN				
1082	Line item identifier	C an..6	R n..6	Line Item Number
1229	Action request/notification description code	C an..3	N	not used
C212	Item number identification	C	R	
7140	Item identifier	C an..35	R an..35	Buyer's Article Number
7143	Item type identification code	C an..3	R an..3	
				IN = Buyer's item number
1131	Code list identification code	C an..17	N	not used
3055	Code list responsible agency code	C an..3	N	not used
C829	Sub-line information	C	N	not used
5495	Sub-line indicator code	C an..3	N	not used
1082	Line item identifier	C an..6	N	not used
1222	Configuration level number	C n..2	N	not used
7083	Configuration operation code	C an..3	N	not used

Remark:

Example:

LIN+1+++1234567890:IN'

TRUCK SHOP ORDER

UN/EDIFACT Message: Segment details

Group: **SG28** Status: R Max. Occ.: 200000 Line item section

Segment: **PIA** Seq. No.: 17 Level: 2 **Additional product id**
 Status: D Max. Occ.: 1
 Counter: 1050

Name: **Additional article identifier**

Description of segment:

UN/EDIFACT			Implementation	
	Name	St Format	St Format	Use / Remarks
PIA				
4347	Product identifier code qualifier	M an..3	M an..3	1 = Additional identification
C212	Item number identification	M	R	
7140	Item identifier	C an..35	R an..35	Sellers Article Number
7143	Item type identification code	C an..3	R an..3	
				SA = Supplier's article number
1131	Code list identification code	C an..17	N	not used
3055	Code list responsible agency code	C an..3	N	not used
C212	Item number identification	C	N	not used
7140	Item identifier	C an..35	N	not used
7143	Item type identification code	C an..3	N	not used
1131	Code list identification code	C an..17	N	not used
3055	Code list responsible agency code	C an..3	N	not used
C212	Item number identification	C	N	not used
7140	Item identifier	C an..35	N	not used
7143	Item type identification code	C an..3	N	not used
1131	Code list identification code	C an..17	N	not used
3055	Code list responsible agency code	C an..3	N	not used
C212	Item number identification	C	N	not used
7140	Item identifier	C an..35	N	not used
7143	Item type identification code	C an..3	N	not used
1131	Code list identification code	C an..17	N	not used
3055	Code list responsible agency code	C an..3	N	not used
C212	Item number identification	C	N	not used
7140	Item identifier	C an..35	N	not used
7143	Item type identification code	C an..3	N	not used
1131	Code list identification code	C an..17	N	not used
3055	Code list responsible agency code	C an..3	N	not used

Remark:
 Will only be present in order when available

Example:
 PIA+1+987654321:SA'

TRUCK SHOP ORDER

UN/EDIFACT Message: Segment details

Group: **SG28** Status: R Max. Occ.: 200000 Line item section

Segment: **IMD** Seq. No.: 18 Level: 2 **Item description**
 Status: R Max. Occ.: 1
 Counter: 1060

Name: **Item description**

Description of segment:

UN/EDIFACT			Implementation	
	Name	St Format	St Format	Use / Remarks
IMD				
7077	Description format code	C an..3	R an..3	F = Free-form
C272	Item characteristic	C	N	not used
7081	Item characteristic code	C an..3	N	not used
1131	Code list identification code	C an..17	N	not used
3055	Code list responsible agency code	C an..3	N	not used
C273	Item description	C	R	
7009	Item description code	C an..17	N	not used
1131	Code list identification code	C an..17	N	not used
3055	Code list responsible agency code	C an..3	N	not used
7008	Item description	C an..256	R an..256	
7008	Item description	C an..256	N	not used
3453	Language name code	C an..3	N	not used
7383	Surface or layer code	C an..3	N	not used

Remark:

Example:

IMD+F+++ : : GADGETS '

TRUCK SHOP ORDER

UN/EDIFACT Message: Segment details

Group: **SG28** Status: R Max. Occ.: 200000 Line item section

Segment: **QTY** Seq. No.: 19 Level: 2 **Quantity**
 Status: R Max. Occ.: 1
 Counter: 1080

Name: **Quantity**

Description of segment:

UN/EDIFACT			Implementation	
	Name	St Format	St Format	Use / Remarks
QTY				
C186	Quantity details	M	M	
6063	Quantity type code qualifier	M an..3	M an..3	
6060	Quantity	M an..35	M an..35	21 = Ordered quantity
6411	Measurement unit code	C an..8	D an..8	If no unit code is given the default value is EA for pieces EA = each LTR = litre KGM = kilogram MTR = metre

Remark:

Example:

QTY+21:100'

TRUCK SHOP ORDER

UN/EDIFACT Message: Segment details

Group: **SG32** Status: D Max. Occ.: 1 PRI

Segment: **PRI** Seq. No.: 20 Level: 2 **Price details**
 Status: R Max. Occ.: 1
 Counter: 1330

Name: **Price details**

Description of segment:

UN/EDIFACT			Implementation	
	Name	St Format	St Format	Use / Remarks
PRI				
C509	Price information	C	M	
5125	Price code qualifier	M an..3	M an..3	
5118	Price amount	C n..15	R n..15	AAA = Calculation net Price with 2 decimals
5375	Price type code	C an..3	N	not used
5387	Price specification code	C an..3	N	not used
5284	Unit price basis quantity	C n..9	R n..9	The quantity multipel of the given price Example: 1, 10, 100, 1000
6411	Measurement unit code	C an..8	N	not used
5213	Sub-line item price change operation code	C an..3	N	not used

Remark:
Will only be present in order when available

Example:
PRI+AAA:52.53:::1'

TRUCK SHOP ORDER

UN/EDIFACT Message: Segment details

Group: **SG33** Status: R Max. Occ.: 1 RFF

Segment: **RFF** Seq. No.: 21 Level: 2 **Reference**
 Status: M Max. Occ.: 1
 Counter: 1390

Name: Vips order line number

Description of segment:

UN/EDIFACT			Implementation	
	Name	St Format	St Format	Use / Remarks
RFF				
C506	Reference	M	M	
1153	Reference code qualifier	M an..3	M an..3	
1154	Reference identifier	C an..70	N	ON = Buyers order number not used
1156	Document line identifier	C an..6	R an..6	Vips order line number. Must be returned in Invoice
4000	Reference version identifier	C an..35	N	not used
1060	Revision identifier	C an..6	N	not used

Remark:

Example:

RFF+ON : :10'

TRUCK SHOP ORDER

UN/EDIFACT Message: Segment details

Segment: **UNS** Seq. No.: 22 Level: 0 **Section control**
Status: M Max. Occ.: 1
Counter: 2330

Name: Section control

Description of segment:

UN/EDIFACT		Implementation		
	Name	St Format	St Format	Use / Remarks
UNS 0081	Section identification	M a1	M a1	D = Header/detail section separation

Remark:

Example:

UNS+D'

TRUCK SHOP ORDER

UN/EDIFACT Message: Segment details

Segment: **UNT** Seq. No.: 23 Level: 0 **Message trailer**
Status: M Max. Occ.: 1
Counter: 2400

Name: Message trailer

Description of segment:

UN/EDIFACT		Implementation		
	Name	St Format	St Format	Use / Remarks
UNT				
0074	Number of segments in the message	M n..6	M n..6	Number of segments in the message
0062	Message reference number	M an..14	M an..14	

Remark:

Example:

UNT+22+10045'