



Message Specification

VOLVO GLOBAL 860 4050

Based on:

860

Purchase Order Change Request - Buyer Initiated

X12 004050

Version: 1.0
Issue date: 2018-10-02
Author: Volvo Group IT

Message Structure

Counter	No	Tag	St	MaxOcc	Level	Content
0100	1	ST	M	1	0	Transaction Set Header
0200	2	BCH	M	1	0	Beginning Segment for Purchase Order Change
0400	3	CUR	D	1	0	Currency
0500	4	REF	D	99	1	Dealer purchase order number
0500	5	REF	D	99	1	Customer Reference Number
0500	6	REF	D	99	1	Purchase Description
0500	7	REF	D	1	1	Billing account number
0500	8	REF	D	1	1	Criticality Designator
0500	9	REF	D	99	1	Promotion/Deal Number
0800	10	FOB	D	1	1	F.O.B. Related Instructions
1500	11	DTM	R	1	1	Date/Time Reference
2400	12	TD5	D	1	1	Carrier Details (Routing Sequence/Transit Time)
2850		N9	D	3	1	N9-MTX
2850	13	N9	M	1	1	Extended Reference Information
2900	14	MTX	R	1	2	Text
3000		N1	R	1	1	Buyer
3000	15	N1	M	1	1	Party Identification
3200	16	N3	O	1	2	Party Location
3300	17	N4	R	1	2	Geographic Location
3400	18	REF	D	1	2	Reference Information
3500	19	PER	O	3	2	Administrative Communications Contact
3000		N1	D	1	1	Bill-to-Party
3000	20	N1	M	1	1	Party Identification
3200	21	N3	O	1	2	Party Location
3300	22	N4	R	1	2	Geographic Location
3400	23	REF	D	1	2	Reference Information
3000		N1	R	1	1	Selling Party
3000	24	N1	M	1	1	Party Identification
3200	25	N3	O	1	2	Party Location
3300	26	N4	R	1	2	Geographic Location
3400	27	REF	D	1	2	Reference Information
3500	28	PER	O	3	2	Administrative Communications Contact
3000		N1	D	1	1	Consolidator
3000	29	N1	M	1	1	Party Identification
3200	30	N3	O	1	2	Party Location
3300	31	N4	R	1	2	Geographic Location
3000		N1	R	1	1	Ship To
3000	32	N1	M	1	1	Party Identification
3200	33	N3	O	1	2	Party Location

Counter = Counter of segment/group within the standard
 No = Consecutive segment number
 MaxOcc = Maximum occurrence of the segment/group

St = Status
 STANDARD: M=Mandatory, C=Conditional
 User specific: R=Required, O=Optional, D=Dependent,
 A=Advised, N=Not used

Counter	No	Tag	St	MaxOcc	Level	Content
3300	34	N4	R	1	2	Geographic Location
3400	35	REF	D	1	2	Reference Information
3000		N1	D	1	1	Final Customer Organization
3000	36	N1	M	1	1	Party Identification
3200	37	N3	O	1	2	Party Location
3300	38	N4	R	1	2	Geographic Location
0100		POC	R	999	1	POC-CTP-REF-REF-DTM-MTX-SCH
0100	39	POC	M	1	1	Line Item Change
0400	40	CTP	D	1	2	Pricing Information
1000	41	REF	D	10	2	Characteristic Code Description
1000	42	REF	D	1	2	Reference Information
2000	43	DTM	D	10	2	Date/Time Reference
2920	44	MTX	D	3	2	Text
2950		SCH	O	100	2	Scheduling Details
2950	45	SCH	M	1	2	Line Item Schedule
3160	46	REF	R	1	3	Scheduling Conditions
0100		CTT	O	1	1	CTT
0100	47	CTT	M	1	1	Transaction Totals
0300	48	SE	M	1	0	Transaction Set Trailer

Counter = Counter of segment/group within the standard
 No = Consecutive segment number
 MaxOcc = Maximum occurrence of the segment/group

St = Status
 STANDARD: M=Mandatory, C=Conditional
 User specific: R=Required, O=Optional, D=Dependent,
 A=Advised, N=Not used

Branching Diagram of Used Segments/Groups

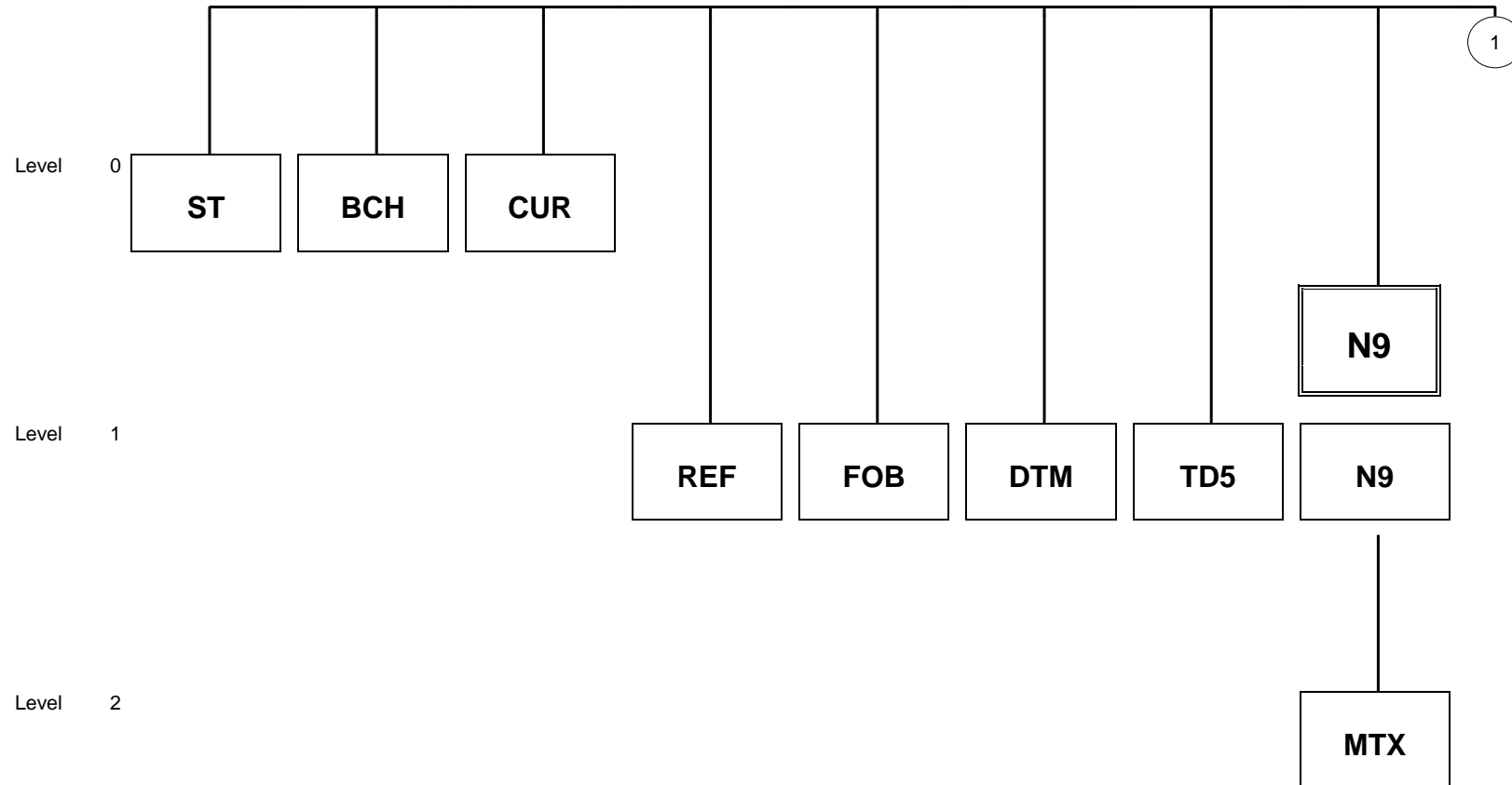

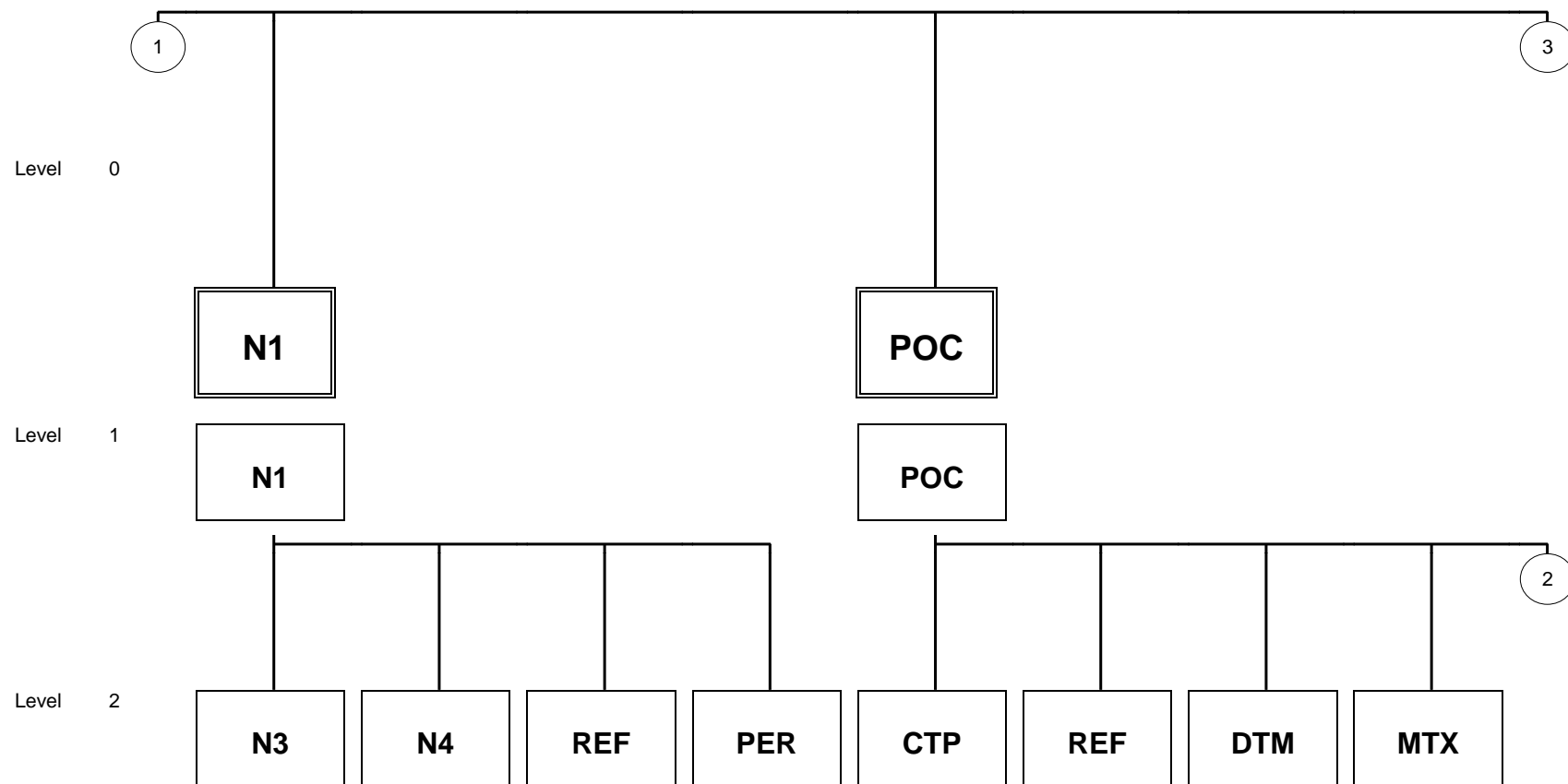

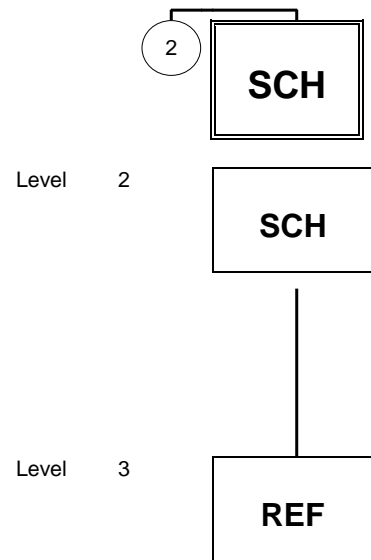

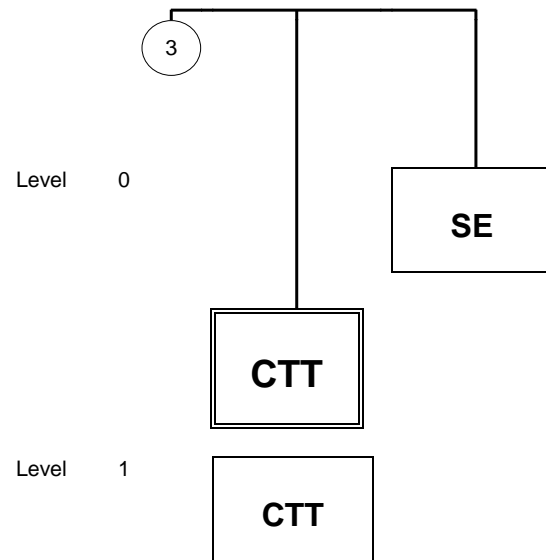

Segment: **ST** Seq. No.: 1 Level: 0 Transaction Set Header
 Status: M Max. Occ.: 1
 Counter: 0100

Name: Transaction Set Header

UN/EDIFACT			Implementation	
	Name	St Format	St Format	Use / Remarks
ST				
143	Transaction Set Identifier Code	M ID 3/3	M ID 3/3	Code uniquely identifying a Transaction Set 860 Purchase Order Change Request - Buyer Initiated
329	Transaction Set Control Number	M AN 4/9	M AN 4/9	Identifying control number that must be unique within the transaction set functional group assigned by the originator for a transaction set

Remark:

Example:

ST*860*789456

Segment:

BCH

Seq. No.: 2 Level: 0
 Status: M Max. Occ.: 1
 Counter: 0200

Beginning Segment for Purchase Order Change

Name: **Beginning Segment for Purchase Order Change**

UNEDIFACT			Implementation	
	Name	St Format	St Format	Use / Remarks
BCH				
353	Transaction Set Purpose Code	M ID 2/2	M ID 2/2	01 Cancellation 04 Change 05 Replace
92	Purchase Order Type Code	M ID 2/2	M ID 2/2	BE Blanket Order/Estimated Quantities (Not firm Commitment) SA Stand-alone Order CF Confirmation
324	Purchase Order Number	M AN 1/22	M AN 1/22	Order Number
328	Release Number	O AN 1/30	N	not used
327	Change Order Sequence Number	O AN 1/8	N	not used
373	Date	M DT 8/8	M DT 8/8	
326	Request Reference Number	O AN 1/45	N	not used
367	Contract Number	O AN 1/30	N	not used
127	Reference Identification	O AN 1/50	N	not used
373	Date	O DT 8/8	N	not used
373	Date	O DT 8/8	N	not used
1166	Contract Type Code	O ID 2/2	N	not used
786	Security Level Code	O ID 2/2	N	not used
587	Acknowledgment Type	O ID 2/2	O ID 2/2	AC Acknowledge - With Detail and Change AE Acknowledge - With Exception Detail Only NA No Acknowledgment Needed ZZ Mutually Defined (Acknowledgement when error) AC - an 855 is expected for each 850 or 860 AE - an 855 is always expected. If there is any kind of deviation from normal, detail should be provided, as for example: Back order, Price error, Substituted part, etc. ZZ - an 855 is expected when there is any kind of deviation from normal as for example: Back order, Price error, Substituted part, etc.

Remark:

Example:

BCH*05*SA*5372D-45962***20160519*****AC

Segment: **CUR** Seq. No.: 3 Level: 0 Currency
 Status: D Max. Occ.: 1
 Counter: 0400

Name: **Currency**

UN/EDIFACT			Implementation	
	Name	St Format	St Format	Use / Remarks
CUR				
98	Entity Identifier Code	M ID 2/3	M ID 2/2	BY Buying Party (Purchaser)
100	Currency Code	M ID 3/3	M ID 3/3	Order currency ISO 4217 three alpha code

Remark:
 Used according to agreement between concerned parties.

Example:
 CUR*BY*USD

Segment:

REF

Seq. No.: 4 Level: 1
 Status: D Max. Occ.: 99
 Counter: 0500

Reference Information

Name: **Dealer purchase order number**

UN/EDIFACT			Implementation	
	Name	St Format	St Format	Use / Remarks
REF				
128	Reference Identification Qualifier	M ID 2/3	M ID 2/2	DC Dealer purchase order number E.g. Original purchase order
127	Reference Identification	C AN 1/50	R AN 1/50	

Remark:

Used according to agreement between concerned parties.

Example:

REF*DC*OP08058

Segment:

REF

Seq. No.: 5 Level: 1
 Status: D Max. Occ.: 99
 Counter: 0500

Reference Information

Name: **Customer Reference Number**

UN/EDIFACT			Implementation	
	Name	St Format	St Format	Use / Remarks
REF				
128	Reference Identification Qualifier	M ID 2/3	M ID 2/2	CR Customer Reference Number
127	Reference Identification	C AN 1/50	R AN 1/50	

Remark:

Used according to agreement between concerned parties.

Example:

REF*CR*1011176105

Segment:

REF

Seq. No.: 6 Level: 1
 Status: D Max. Occ.: 99
 Counter: 0500

Reference Information

Name: **Purchase Description**

UN/EDIFACT			Implementation	
	Name	St Format	St Format	Use / Remarks
REF				
128	Reference Identification Qualifier	M ID 2/3	M ID 2/2	K6 Purchase Description
127	Reference Identification	C AN 1/50	R AN 1/50	

Remark:

Used according to agreement between concerned parties.

Example:

REF*K6*VP__123456

Segment:

REF

Seq. No.: 7 Level: 1
 Status: D Max. Occ.: 1
 Counter: 0500

Reference Information

Name: **Billing account number**

UN/EDIFACT			Implementation	
	Name	St Format	St Format	Use / Remarks
REF				
128	Reference Identification Qualifier	M ID 2/3	M ID 2/2	12 Billing Account
127	Reference Identification	C AN 1/50	R AN 1/50	Billing account number

Remark:

Used according to agreement between concerned parties.

Example:

REF*12*123456

Segment:

REF

Seq. No.: 8 Level: 1
 Status: D Max. Occ.: 1
 Counter: 0500

Reference Information

Name: **Criticality Designator**

UN/EDIFACT			Implementation	
	Name	St Format	St Format	Use / Remarks
REF				
128	Reference Identification Qualifier	M ID 2/3	M ID 2/2	K4 Criticality Designator
127	Reference Identification	C AN 1/50	R AN 1/50	1 If an EMERGENCY order 3 If a STOCK order

Remark:

Used according to agreement between concerned parties.

Example:

REF*K4*1

Segment:

REF

Seq. No.: 9 Level: 1
 Status: D Max. Occ.: 99
 Counter: 0500

Reference Information

Name: Promotion/Deal Number

UN/EDIFACT			Implementation	
	Name	St Format	St Format	Use / Remarks
REF				
128	Reference Identification Qualifier	M ID 2/3	M ID 2/2	PD Promotion/Deal Number
127	Reference Identification	C AN 1/50	R AN 1/50	

Remark:

Used according to agreement between concerned parties.

Example:

REF*PD*025

Segment:

FOB

Seq. No.: 10 Level: 1
 Status: D Max. Occ.: 1
 Counter: 0800

F.O.B. Related Instructions

Name: F.O.B. Related Instructions

UN/EDIFACT			Implementation	
	Name	St Format	St Format	Use / Remarks
FOB				
146	Shipment Method of Payment	M ID 2/2	M ID 2/2	DF Defined by Buyer and Seller
309	Location Qualifier	C ID 1/2	D ID 1/2	EA Event Location
352	Description	O AN 1/80	D AN 1/35	Location Name
334	Transportation Terms Qualifier Code	O ID 2/2	R ID 2/2	01 Incoterms
335	Transportation Terms Code	C ID 3/3	R ID 3/3	INCOTERMS® 2010 version released by International Chamber of Commerce (ICC). It is to be noted that contracts made under INCOTERMS® 2000 can remain valid.

Remark:

Used according to agreement between concerned parties.

Example:

FOB*DF*EA*TORONTO*01*FCA

Segment:

DTM

Seq. No.: 11 Level: 1
 Status: R Max. Occ.: 1
 Counter: 1500

Date/Time Reference

Name: Date/Time Reference

UN/EDIFACT			Implementation	
	Name	St Format	St Format	Use / Remarks
DTM				
374	Date/Time Qualifier	M ID 3/3	M ID 3/3	999 Document Date
373	Date	C DT 8/8	R DT 8/8	Same as 0200 BCH data element/tag 373.
337	Time	C TM 4/8	O TM 4/6	Time expressed in 24-hour clock time as follows: HHMM, or HHMMSS

Remark:

Example:

DTM*999*20160519*1547

Segment:

TD5

Seq. No.: 12 Level: 1
 Status: D Max. Occ.: 1
 Counter: 2400

Carrier Details (Routing Sequence/Transit Time)

Name: Carrier Details (Routing Sequence/Transit Time)

UN/EDIFACT			Implementation	
	Name	St Format	St Format	Use / Remarks
TD5				
133	Routing Sequence Code	O ID 1/2	N	not used
66	Identification Code Qualifier	C ID 1/2	C ID 1/2	2 92 Standard Carrier Alpha Code (SCAC) Assigned by Buyer or Buyer's Agent
67	Identification Code	C AN 2/80	C AN 2/80	
91	Transportation Method/Type Code	C ID 1/2	N	not used
387	Routing	C AN 1/35	C AN 1/35	Free-form description of the routing or requested routing for shipment, or the originating carrier's identity
368	Shipment/Order Status Code	C ID 2/2	N	not used
309	Location Qualifier	O ID 1/2	N	not used
310	Location Identifier	C AN 1/30	N	not used
731	Transit Direction Code	O ID 2/2	N	not used
732	Transit Time Direction Qualifier	O ID 2/2	N	not used
733	Transit Time	C R 1/4	N	not used
284	Service Level Code	C ID 2/2	D ID 2/2	9A 9 A.M. AC Air Cargo AM A.M. CG Ground CX Express Service ES Expedited Service G2 Standard Service GT Tracking - Ground IE Expedited Service - Worldwide IX Express Service - Worldwide ND Next Day Air Delivery during day hours of next business day NM Next Morning ON Overnight SA Same Day SC Second Day Air Delivery during day hours no later than 2nd business day SD Saturday SE Second Day SG Standard Ground SH Second Day Hundred Weight SI Standard Ground Hundred Weight SM Second Morning Used according to agreement between concerned parties.

Remark:

Used according to agreement between concerned parties.

Example:

TD5**2*456DFG**UPS OVERNIGHT*****CG

Group: **N9** Status: D Max. Occ.: 3 N9-MTX

Used according to agreement between concerned parties.

Segment: **N9** Seq. No.: 13 Level: 1 **Extended Reference Information**
 Status: M Max. Occ.: 1
 Counter: 2850

Name: **Extended Reference Information**

UN/EDIFACT			Implementation	
	Name	St Format	St Format	Use / Remarks
N9				
128	Reference Identification Qualifier	M ID 2/3	M ID 2/3	82 Data Item Description (DID) Reference

Remark:

Example:

N9*82

Group: **N9** Status: D Max. Occ.: 3 N9-MTX

Used according to agreement between concerned parties.

Segment: **MTX** Seq. No.: 14 Level: 2 **Text**
 Status: R Max. Occ.: 1
 Counter: 2900

Name: Text

UN/EDIFACT		Implementation		
	Name	St Format	St Format	Use / Remarks
MTX				
363	Note Reference Code	O ID 3/3	R ID 3/3	ADD PUR TSD Additional Information Purchasing Terms of Sale Description
1551	Textual Data	C AN 1/40	R AN 1/80	

Remark:

To provide free form or coded text information. In general free text should be avoided where possible since this will inhibit automatic processing.

Example:

MTX*ADD*ADDITIONAL INFORMATION

Group: **N1** Status: R Max. Occ.: 1 Buyer

Segment: **N1** Seq. No.: 15 Level: 1 **Party Identification**
 Status: M Max. Occ.: 1
 Counter: 3000

Name: **Party Identification**

UN/EDIFACT			Implementation	
	Name	St Format	St Format	Use / Remarks
N1				
98	Entity Identifier Code	M ID 2/3	M ID 2/2	BY Buying Party (Purchaser)
93	Name	C AN 1/60	R AN 1/60	
66	Identification Code Qualifier	C ID 1/2	R ID 1/2	92 Assigned by Buyer or Buyer's Agent
67	Identification Code	C AN 2/80	R AN 2/35	

Remark:

N1*BY tells who the buyer is.
 Buyer can also be the Ship to party. If this is the case N1*BY and N1*ST contains same information.
 Buyer can also be the party to invoice. If this is the case N1*BT can be excluded from the message.

Example:

N1*BY*VOLVO TRUCKS NA INC*92*24814

Group: **N1** Status: R Max. Occ.: 1 Buyer

Segment: **N3** Seq. No.: 16 Level: 2 **Party Location**
 Status: O Max. Occ.: 1
 Counter: 3200

Name: Party Location

UN/EDIFACT		Implementation		
	Name	St Format	St Format	Use / Remarks
N3				
166	Address Information	M AN 1/55	M AN 1/55	
166	Address Information	O AN 1/55	N	not used

Remark:

Example:

N3*7900 NATIONAL SERVICE RD

Group: **N1** Status: R Max. Occ.: 1 Buyer

Segment: **N4** Seq. No.: 17 Level: 2 **Geographic Location**
 Status: R Max. Occ.: 1
 Counter: 3300

Name: **Geographic Location**

UN/EDIFACT		Implementation		
	Name	St Format	St Format	Use / Remarks
N4				
19	City Name	O AN 2/30	R AN 2/30	
156	State or Province Code	C ID 2/2	O ID 2/2	
116	Postal Code	O ID 3/15	R ID 3/15	
26	Country Code	C ID 2/3	R ID 2/2	

Remark:

Example:

N4*GREENSBORO*NC*27409*US

Group: **N1** Status: R Max. Occ.: 1 Buyer

Segment: **REF** Seq. No.: 18 Level: 2 **Reference Information**
 Status: D Max. Occ.: 1
 Counter: 3400

Name: **Reference Information**

UN/EDIFACT			Implementation	
	Name	St Format	St Format	Use / Remarks
REF				
128	Reference Identification Qualifier	M ID 2/3	M ID 2/2	VX Value-Added Tax Registration Number (Europe)
127	Reference Identification	C AN 1/50	R AN 1/17	

Remark:

Used according to agreement between concerned parties.

Example:

REF*VX*SE556013970001

Group: **N1** Status: R Max. Occ.: 1 Buyer

Segment: **PER** Seq. No.: 19 Level: 2 **Administrative Communications Contact**
 Status: O Max. Occ.: 3
 Counter: 3500

Name: **Administrative Communications Contact**

UN/EDIFACT			Implementation	
	Name	St Format	St Format	Use / Remarks
PER				
366	Contact Function Code	M ID 2/2	M ID 2/2	BD Buyer Name or Department
93	Name	O AN 1/60	R AN 1/35	
365	Communication Number Qualifier	C ID 2/2	C ID 2/2	EM Electronic Mail
364	Communication Number	C AN 1/25	C AN 1/70	
365	Communication Number Qualifier	C ID 2/2	C ID 2/2	TE Telephone
364	Communication Number	C AN 1/25	C AN 1/70	
365	Communication Number Qualifier	C ID 2/2	C ID 2/2	FX Facsimile
364	Communication Number	C AN 1/25	C AN 1/70	

Remark:

Example:

PER*BD*BOB SNYDER*EM*BOB.SNYDER@VOLVO.COM

Group: **N1** Status: D Max. Occ.: 1 Bill-to-Party

Segment: **N1** Seq. No.: 20 Level: 1 **Party Identification**
 Status: M Max. Occ.: 1
 Counter: 3000

Name: Party Identification

UN/EDIFACT			Implementation	
	Name	St Format	St Format	Use / Remarks
N1				
98	Entity Identifier Code	M ID 2/3	M ID 2/2	BT Bill-to-Party
93	Name	C AN 1/60	R AN 1/60	
66	Identification Code Qualifier	C ID 1/2	R ID 1/2	92 Assigned by Buyer or Buyer's Agent
67	Identification Code	C AN 2/80	R AN 2/35	

Remark:

N1*BT tells where to send the invoice. If not given it is the same as Buyer.

Example:

N1*BT*VOLVO TRUCKS NA INC*92*24814

Group: **N1** Status: D Max. Occ.: 1 Bill-to-Party

Segment: **N3** Seq. No.: 21 Level: 2 **Party Location**
 Status: O Max. Occ.: 1
 Counter: 3200

Name: Party Location

UN/EDIFACT		Implementation		
	Name	St Format	St Format	Use / Remarks
N3				
166	Address Information	M AN 1/55	M AN 1/55	
166	Address Information	O AN 1/55	N	not used

Remark:

Example:

N3*7900 NATIONAL SERVICE RD

Group: **N1** Status: D Max. Occ.: 1 Bill-to-Party

Segment: **N4** Seq. No.: 22 Level: 2 **Geographic Location**
 Status: R Max. Occ.: 1
 Counter: 3300

Name: **Geographic Location**

UN/EDIFACT		Implementation		
	Name	St Format	St Format	Use / Remarks
N4				
19	City Name	O AN 2/30	R AN 2/30	
156	State or Province Code	C ID 2/2	O ID 2/2	
116	Postal Code	O ID 3/15	R ID 3/15	
26	Country Code	C ID 2/3	R ID 2/2	

Remark:

Example:

N4*GREENSBORO*NC*27409*US

Group: **N1** Status: D Max. Occ.: 1 Bill-to-Party

Segment: **REF** Seq. No.: 23 Level: 2 **Reference Information**
 Status: D Max. Occ.: 1
 Counter: 3400

Name: Reference Information

UN/EDIFACT			Implementation	
	Name	St Format	St Format	Use / Remarks
REF				
128	Reference Identification Qualifier	M ID 2/3	M ID 2/2	VX Value-Added Tax Registration Number (Europe)
127	Reference Identification	C AN 1/50	R AN 1/17	

Remark:

Used according to agreement between concerned parties.

Example:

REF*VX*DK26178509

Group: **N1** Status: R Max. Occ.: 1 Selling Party

Segment: **N1** Seq. No.: 24 Level: 1 **Party Identification**
 Status: M Max. Occ.: 1
 Counter: 3000

Name: Party Identification

UN/EDIFACT			Implementation	
	Name	St Format	St Format	Use / Remarks
N1				
98	Entity Identifier Code	M ID 2/3	M ID 2/2	SE Selling Party
93	Name	C AN 1/60	R AN 1/60	
66	Identification Code Qualifier	C ID 1/2	R ID 1/2	92 Assigned by Buyer or Buyer's Agent
67	Identification Code	C AN 2/80	R AN 2/35	

Remark:

N1*SE tells who the seller is.

Example:

N1*SE*PANA-PACIFIC CORP*92*51144

Group: **N1** Status: R Max. Occ.: 1 Selling Party

Segment: **N3** Seq. No.: 25 Level: 2 **Party Location**
 Status: O Max. Occ.: 1
 Counter: 3200

Name: Party Location

UN/EDIFACT		Implementation		
	Name	St Format	St Format	Use / Remarks
N3				
166	Address Information	M AN 1/55	M AN 1/55	
166	Address Information	O AN 1/55	N	not used

Remark:

Example:

N3*80 VANESS DR

Group: **N1** Status: R Max. Occ.: 1 Selling Party

Segment: **N4** Seq. No.: 26 Level: 2 **Geographic Location**
 Status: R Max. Occ.: 1
 Counter: 3300

Name: **Geographic Location**

UN/EDIFACT		Implementation		
	Name	St Format	St Format	Use / Remarks
N4				
19	City Name	O AN 2/30	R AN 2/30	
156	State or Province Code	C ID 2/2	O ID 2/2	
116	Postal Code	O ID 3/15	R ID 3/15	
26	Country Code	C ID 2/3	R ID 2/2	

Remark:

Example:

N4*ENCINO*CA*93721*US

Group: **N1** Status: R Max. Occ.: 1 Selling Party

Segment: **REF** Seq. No.: 27 Level: 2 **Reference Information**
 Status: D Max. Occ.: 1
 Counter: 3400

Name: Reference Information

UN/EDIFACT			Implementation	
	Name	St Format	St Format	Use / Remarks
REF				
128	Reference Identification Qualifier	M ID 2/3	M ID 2/2	VX Value-Added Tax Registration Number (Europe)
127	Reference Identification	C AN 1/50	R AN 1/17	

Remark:

Used according to agreement between concerned parties.

Example:

REF*VX*DK30722566

Group: **N1** Status: R Max. Occ.: 1 Selling Party

Segment: **PER** Seq. No.: 28 Level: 2 **Administrative Communications Contact**
 Status: O Max. Occ.: 3
 Counter: 3500

Name: **Administrative Communications Contact**

UN/EDIFACT			Implementation		
	Name	St Format	St Format	Use / Remarks	
PER					
366	Contact Function Code	M ID 2/2	M ID 2/2	SU	Supplier Contact
93	Name	O AN 1/60	R AN 1/35		
365	Communication Number Qualifier	C ID 2/2	C ID 2/2	EM	Electronic Mail
364	Communication Number	C AN 1/25	C AN 1/70		
365	Communication Number Qualifier	C ID 2/2	C ID 2/2	TE	Telephone
364	Communication Number	C AN 1/25	C AN 1/70		
365	Communication Number Qualifier	C ID 2/2	C ID 2/2	FX	Facsimile
364	Communication Number	C AN 1/25	C AN 1/70		

Remark:

Example:

PER*SU*SUPPLIER NAME*EM*NAME@COMPANY.COM

Group: **N1** Status: D Max. Occ.: 1 Consolidator

Used according to agreement between concerned parties.

Segment: **N1** Seq. No.: 29 Level: 1 **Party Identification**
 Status: M Max. Occ.: 1
 Counter: 3000

Name: **Party Identification**

UN/EDIFACT			Implementation	
	Name	St Format	St Format	Use / Remarks
N1				
98	Entity Identifier Code	M ID 2/3	M ID 2/2	CS Consolidator
93	Name	C AN 1/60	R AN 1/60	
66	Identification Code Qualifier	C ID 1/2	R ID 1/2	92 Assigned by Buyer or Buyer's Agent
67	Identification Code	C AN 2/80	R AN 2/35	

Remark:

The Consolidator is a logistics party who consolidates shipments to one Ship to party. The party is in charge of groupage, including degroupage and regroupage.

Example:

N1*CS*CONSOLIDATING COMPANY*92*12345678

Group: **N1** Status: D Max. Occ.: 1 Consolidator
 Used according to agreement between concerned parties.

Segment: **N3** Seq. No.: 30 Level: 2 **Party Location**
 Status: O Max. Occ.: 1
 Counter: 3200

Name: Party Location

UN/EDIFACT		Implementation		
	Name	St Format	St Format	Use / Remarks
N3				
166	Address Information	M AN 1/55	M AN 1/55	
166	Address Information	O AN 1/55	N	not used

Remark:

Example:

N3*STREET NAME

Group: **N1** Status: D Max. Occ.: 1 Consolidator

Used according to agreement between concerned parties.

Segment: **N4** Seq. No.: 31 Level: 2 **Geographic Location**
 Status: R Max. Occ.: 1
 Counter: 3300

Name: **Geographic Location**

UN/EDIFACT		Implementation		
	Name	St Format	St Format	Use / Remarks
N4				
19	City Name	O AN 2/30	R AN 2/30	
156	State or Province Code	C ID 2/2	C ID 2/2	
116	Postal Code	O ID 3/15	R ID 3/15	
26	Country Code	C ID 2/3	R ID 2/2	

Remark:

Example:

N4*GREENSBORO*NC*27409*US

Group: **N1** Status: R Max. Occ.: 1 Ship To

Segment: **N1** Seq. No.: 32 Level: 1 **Party Identification**
 Status: M Max. Occ.: 1
 Counter: 3000

Name: **Party Identification**

UN/EDIFACT			Implementation	
	Name	St Format	St Format	Use / Remarks
N1				
98	Entity Identifier Code	M ID 2/3	M ID 2/2	ST Ship To
93	Name	C AN 1/60	R AN 1/60	
66	Identification Code Qualifier	C ID 1/2	R ID 1/2	92 Assigned by Buyer or Buyer's Agent
67	Identification Code	C AN 2/80	R AN 2/35	

Remark:

N1*ST tells where to send the goods, unless an agreement exists to send the goods to the Consolidator or the Final Customer Organization.

Example:

N1*ST*WORLDWIDE EQUIPMENT OF TN, INC*92*5372D

Group: **N1** Status: R Max. Occ.: 1 Ship To

Segment: **N3** Seq. No.: 33 Level: 2 **Party Location**
 Status: O Max. Occ.: 1
 Counter: 3200

Name: Party Location

UN/EDIFACT		Implementation		
	Name	St Format	St Format	Use / Remarks
N3				
166	Address Information	M AN 1/55	M AN 1/55	
166	Address Information	O AN 1/55	N	not used

Remark:

Example:

N3*2017 EAST 23RD STREET

Group: **N1** Status: R Max. Occ.: 1 Ship To

Segment: **N4** Seq. No.: 34 Level: 2 **Geographic Location**
 Status: R Max. Occ.: 1
 Counter: 3300

Name: **Geographic Location**

UN/EDIFACT		Implementation		
	Name	St Format	St Format	Use / Remarks
N4				
19	City Name	O AN 2/30	R AN 2/30	
156	State or Province Code	C ID 2/2	C ID 2/2	
116	Postal Code	O ID 3/15	R ID 3/15	
26	Country Code	C ID 2/3	R ID 2/2	

Remark:

Example:

N4*CHATTANOOGA*TN*37404*US

Group: **N1** Status: R Max. Occ.: 1 Ship To

Segment: **REF** Seq. No.: 35 Level: 2 **Reference Information**
 Status: D Max. Occ.: 1
 Counter: 3400

Name: Reference Information

UN/EDIFACT		Implementation		
	Name	St Format	St Format	Use / Remarks
REF				
128	Reference Identification Qualifier	M ID 2/3	M ID 2/2	DK Dock Number
127	Reference Identification	C AN 1/50	R AN 1/35	

Remark:
 Used according to agreement between concerned parties.

Example:
 REF*DK*200A

Group: **N1** Status: D Max. Occ.: 1 Final Customer Organization
 Used according to agreement between concerned parties.

Segment: **N1** Seq. No.: 36 Level: 1 **Party Identification**
 Status: M Max. Occ.: 1
 Counter: 3000

Name: **Party Identification**

UN/EDIFACT			Implementation		
	Name	St Format	St Format	Use / Remarks	
N1					
98	Entity Identifier Code	M ID 2/3	M ID 2/2	XT	Final Customer Organization
93	Name	C AN 1/60	R AN 1/60		
66	Identification Code Qualifier	C ID 1/2	R ID 1/2	92	Assigned by Buyer or Buyer's Agent
67	Identification Code	C AN 2/80	R AN 2/35		

Remark:

The Final Customer Organization is the final recipient of the goods. In a multi-tier scheduled shipment it might be necessary to distinguish between the Seller or the Ship from (e.g. tier 2), the Ship to (e.g. tier 1) and the Final Customer Organization (e.g. OEM's plant, car dealer or commercial parts seller). This segment will only be used when the final recipient is different from the Ship to party.

Example:

N1*XT*FINAL CUSTOMER COMPANY*92*235689

Group: **N1** Status: D Max. Occ.: 1 Final Customer Organization
 Used according to agreement between concerned parties.

Segment: **N3** Seq. No.: 37 Level: 2 **Party Location**
 Status: O Max. Occ.: 1
 Counter: 3200

Name: Party Location

UN/EDIFACT		Implementation		
	Name	St Format	St Format	Use / Remarks
N3				
166	Address Information	M AN 1/55	M AN 1/55	
166	Address Information	O AN 1/55	N	not used

Remark:

Example:

N3*7900 NATIONAL SERVICE RD

Group: **N1** Status: D Max. Occ.: 1 Final Customer Organization
 Used according to agreement between concerned parties.

Segment: **N4** Seq. No.: 38 Level: 2 **Geographic Location**
 Status: R Max. Occ.: 1
 Counter: 3300

Name: **Geographic Location**

UN/EDIFACT			Implementation	
	Name	St Format	St Format	Use / Remarks
N4				
19	City Name	O AN 2/30	R AN 2/30	
156	State or Province Code	C ID 2/2	C ID 2/2	
116	Postal Code	O ID 3/15	R ID 3/15	
26	Country Code	C ID 2/3	R ID 2/2	

Remark:

Example:

N4*GREENSBORO*NC*27409*US

Group: **POC** Status: R Max. Occ.: 999 POC-CTP-REF-DTM-MTX-SCH

Segment: **POC** Seq. No.: 39 Level: 1 Line Item Change
 Status: M Max. Occ.: 1
 Counter: 0100

Name: Line Item Change

UN/EDIFACT			Implementation	
	Name	St Format	St Format	Use / Remarks
POC				
350	Assigned Identification	O AN 1/20	D AN 1/6	Line ID
670	Change or Response Type Code	M ID 2/2	M ID 2/2	CA Changes To Line Items DI Delete Item(s) AI Add Additional Item(s)
380	Quantity	O R 1/15	D R 1/15	Ordered Quantity For split or scheduled deliveries specify the quantities through the repetition of group SCH (Scheduling Details). If split or scheduled deliveries are not used, this data element is required.
671	Quantity Left to Receive	C R 1/9	N	not used
C001	Composite Unit of Measure	C	C	
355	Unit or Basis for Measurement Code	M ID 2/2	M ID 2/2	CN Can CR Cubic Meter DM Decimeter DR Drum EA Each FT Foot GA Gallon GR Gram HU Hundred KG Kilogram KT Kit LB Pound LT Liter ML Milliliter MM Millimeter MR Meter OZ Ounce - Av PK Package PR Pair PT Pint QT Quart SC Square Centimeter SM Square Meter T3 Thousand Pieces If no unit code is given the default value is EA for each/pieces
212	Unit Price	C R 1/17	D R 1/15	
639	Basis of Unit Price Code	O ID 2/2	O ID 2/2	The quantity multipel of the given price HP Price per Hundred PE Price per Each PN Price per Ten TP Price per Thousand
235	Product/Service ID Qualifier	C ID 2/2	R ID 2/2	BP Buyer's Part Number
234	Product/Service ID	C AN 1/48	R AN 1/35	
235	Product/Service ID Qualifier	C ID 2/2	D ID 2/2	VP Vendor's (Seller's) Part Number
234	Product/Service ID	C AN 1/48	D AN 1/35	
235	Product/Service ID Qualifier	C ID 2/2	D ID 2/2	PD Part Number Description
234	Product/Service ID	C AN 1/48	D AN 1/35	
235	Product/Service ID Qualifier	C ID 2/2	D ID 2/2	DR Drawing Revision Number
234	Product/Service ID	C AN 1/48	D AN 1/35	
235	Product/Service ID Qualifier	C ID 2/2	D ID 2/2	EN EAN/UCC - 13

UN/EDIFACT			Implementation	
	Name	St Format	St Format	Use / Remarks
234	Product/Service ID	C AN 1/48	D AN 1/48	

Remark:**Example:**

POC*00001*CA*7**EA*69.60*PE*BP*PNSPP1060626E*VP*PP106062 6E*PD*RADIO,AM/FM CD PLA

Group: **POC** Status: R Max. Occ.: 999 POC-CTP-REF-DTM-MTX-SCH

Segment: **CTP** Seq. No.: 40 Level: 2 Pricing Information
 Status: D Max. Occ.: 1
 Counter: 0400

Name: Pricing Information

UN/EDIFACT			Implementation	
	Name	St Format	St Format	Use / Remarks
CTP				
687	Class of Trade Code	O ID 2/2	N	not used
236	Price Identifier Code	C ID 3/3	N	not used
212	Unit Price	C R 1/17	N	not used
380	Quantity	C R 1/15	N	not used
C001	Composite Unit of Measure	C	N	not used
355	Unit or Basis for Measurement Code	M ID 2/2	N	not used
1018	Exponent	O R 1/15	N	not used
649	Multiplier	O R 1/10	N	not used
355	Unit or Basis for Measurement Code	O ID 2/2	N	not used
1018	Exponent	O R 1/15	N	not used
649	Multiplier	O R 1/10	N	not used
355	Unit or Basis for Measurement Code	O ID 2/2	N	not used
1018	Exponent	O R 1/15	N	not used
649	Multiplier	O R 1/10	N	not used
355	Unit or Basis for Measurement Code	O ID 2/2	N	not used
1018	Exponent	O R 1/15	N	not used
649	Multiplier	O R 1/10	N	not used
355	Unit or Basis for Measurement Code	O ID 2/2	N	not used
1018	Exponent	O R 1/15	N	not used
649	Multiplier	O R 1/10	N	not used
648	Price Multiplier Qualifier	O ID 3/3	N	not used
649	Multiplier	C R 1/10	N	not used
782	Monetary Amount	O R 1/18	N	not used
639	Basis of Unit Price Code	O ID 2/2	R ID 2/2	NT Net (Calculation Net) ST Standard (Calculation Gross)

Remark:
 Used according to agreement between concerned parties.

Example:
 CTP*****NT

Group: **POC** Status: R Max. Occ.: 999 POC-CTP-REF-DTM-MTX-SCH

Segment: **REF** Seq. No.: 41 Level: 2 **Reference Information**
 Status: D Max. Occ.: 10
 Counter: 1000

Name: Characteristic Code Description

UN/EDIFACT			Implementation	
	Name	St Format	St Format	Use / Remarks
REF				
128	Reference Identification Qualifier	M ID 2/3	R ID 2/2	82 Data Item Description (DID) Reference
127	Reference Identification	C AN 1/50	R AN 1/17	
352	Description	C AN 1/80	R AN 1/80	

Remark:

Used according to agreement between concerned parties.

Example:

REF*82*COLOR*BLUE

Group: **POC** Status: R Max. Occ.: 999 POC-CTP-REF-DTM-MTX-SCH

Segment: **REF** Seq. No.: 42 Level: 2 **Reference Information**
 Status: D Max. Occ.: 1
 Counter: 1000

Name: Reference Information

UN/EDIFACT			Implementation	
	Name	St Format	St Format	Use / Remarks
REF				
128	Reference Identification Qualifier	M ID 2/3	R ID 2/2	OQ Order Number
127	Reference Identification	C AN 1/50	D AN 1/50	
352	Description	C AN 1/80	N	not used
C040	Reference Identifier	O	O	
128	Reference Identification Qualifier	M ID 2/3	M ID 2/2	BV Purchase Order Line Item Identifier (Buyer)
127	Reference Identification	M AN 1/50	M AN 1/6	

Remark:

Used according to agreement between concerned parties.

Example:

REF*OQ*5372D-45962-123**BV:10

Group: **POC** Status: R Max. Occ.: 999 POC-CTP-REF-DTM-MTX-SCH

Segment: **DTM** Seq. No.: 43 Level: 2 **Date/Time Reference**
 Status: D Max. Occ.: 10
 Counter: 2000

Name: Date/Time Reference

UN/EDIFACT			Implementation		
	Name	St Format	St Format	Use / Remarks	
DTM					
374	Date/Time Qualifier	M ID 3/3	M ID 3/3	002 010	Delivery Requested Requested Ship
373	Date	C DT 8/8	R DT 8/8		
337	Time	C TM 4/8	C TM 4/6		

Remark:

To specify date (and times if required) relevant to the delivery or pick up of goods.

Example:

DTM*002*20160528*1547

Group: **POC** Status: R Max. Occ.: 999 POC-CTP-REF-DTM-MTX-SCH

Segment: **MTX** Seq. No.: 44 Level: 2 **Text**
 Status: D Max. Occ.: 3
 Counter: 2920

Name: Text

UN/EDIFACT			Implementation		
	Name	St Format	St Format	Use / Remarks	
MTX					
363	Note Reference Code	O ID 3/3	R ID 3/3	ADD PUR TSD	Additional Information Purchasing Terms of Sale Description
1551	Textual Data	C AN 1/40	R AN 1/80		

Remark:

Used according to agreement between concerned parties.
 To provide free form or coded text information. In general free text should be avoided where possible since this will inhibit automatic processing.

Example:

MTX*ADD*FREE TEXT

Group: **POC** Status: R Max. Occ.: 999 POC-CTP-REF-DTM-MTX-SCH

Group: **SCH** Status: O Max. Occ.: 100 Scheduling Details

Segment: **SCH** Seq. No.: 45 Level: 2 **Line Item Schedule**
 Status: M Max. Occ.: 1
 Counter: 2950

Name: Line Item Schedule

UN/EDIFACT			Implementation		
	Name	St Format	St Format	Use / Remarks	
SCH					
380	Quantity	M R 1/15	M R 1/15	On Order Quantity/Ordered quantity	
355	Unit or Basis for Measurement Code	M ID 2/2	M ID 2/2	CN Can CR Cubic Meter DM Decimeter DR Drum EA Each FT Foot GA Gallon GR Gram HU Hundred KG Kilogram KT Kit LB Pound LT Liter ML Milliliter MM Millimeter MR Meter OZ Ounce - Av PK Package PR Pair PT Pint QT Quart SC Square Centimeter SM Square Meter T3 Thousand Pieces If no unit code is given the default value is EA for each/pieces	
98	Entity Identifier Code	O ID 2/3	N	not used	
93	Name	C AN 1/60	N	not used	
374	Date/Time Qualifier	M ID 3/3	M ID 3/3	002 Delivery Requested 010 Requested Ship	
373	Date	M DT 8/8	M DT 8/8		
337	Time	O TM 4/8	O AN 4/6		
374	Date/Time Qualifier	C ID 3/3	N	not used	

Remark:

Example:

SCH*7*EA***002*20160528*1547

Group: **POC** Status: R Max. Occ.: 999 POC-CTP-REF-DTM-MTX-SCH

Group: **SCH** Status: O Max. Occ.: 100 Scheduling Details

Segment: **REF** Seq. No.: 46 Level: 3 **Reference Information**
 Status: R Max. Occ.: 1
 Counter: 3160

Name: **Scheduling Conditions**

UN/EDIFACT			Implementation	
	Name	St Format	St Format	Use / Remarks
REF 128	Reference Identification Qualifier	M ID 2/3	M ID 2/3	Delivery Plan Commitment Level Code ZZ Mutually Defined
127	Reference Identification	C AN 1/50	R AN 1/1	C (Firm) D (Planning) Forecast Qualifier

Remark:

Example:

REF*ZZ*C

Group: CTT Status: O Max. Occ.: 1 CTT

Segment: CTT Seq. No.: 47 Level: 1 **Transaction Totals**
 Status: M Max. Occ.: 1
 Counter: 0100

Name: Transaction Totals

UN/EDIFACT			Implementation	
	Name	St Format	St Format	Use / Remarks
CTT				
354	Number of Line Items	M N0 1/6	M N0 1/6	
347	Hash Total	O R 1/10	O R 1/10	

Remark:

Example:

CTT*9*9

Segment:

SE

Seq. No.: 48 Level: 0
 Status: M Max. Occ.: 1
 Counter: 0300

Transaction Set Trailer

Name: Transaction Set Trailer

UN/EDIFACT		Implementation		
	Name	St Format	St Format	Use / Remarks
SE				
96	Number of Included Segments	M N0 1/10	M N0 1/10	
329	Transaction Set Control Number	M AN 4/9	M AN 4/9	

Remark:

Example:

SE*21*789456