



Message Specification

VOLVO GLOBAL DESADV D07A

Based on:

DESADV

Despatch advice message

UN D.07A S3; JAIF

Version: 1
Variant: 4
Issue date: 24.03.2026
Author: Volvo Group IT

Message Structure

Counter	No	Tag	St	MaxOcc	Level	Content
0010	1	UNH	M	1	0	Message header
0020	2	BGM	M	1	0	Beginning of message
0030	3	DTM	R	1	1	Despatch advice date
0050	4	MEA	D	1	1	Consignment's gross weight
0050	5	MEA	D	1	1	Consignment volume (Total cube)
0080		SG1	R	1	1	Transport document reference
0090	6	RFF	M	1	1	Transport document reference
0080		SG1	D	1	1	Customer reference number
0090	7	RFF	M	1	1	Customer Reference Number
0110		SG2	R	1	1	ShipTo
0120	8	NAD	M	1	1	ShipTo's name and address
0130	9	LOC	R	1	2	Place of discharge
0110		SG2	D	1	1	Buyer
0120	10	NAD	M	1	1	Buyer's name and address
0110		SG2	D	1	1	Ultimate Customer
0120	11	NAD	M	1	1	Ultimate customers's name and address
0110		SG2	D	1	1	Seller
0120	12	NAD	M	1	1	Seller's name and address
0110		SG2	D	1	1	Carrier
0120	13	NAD	M	1	1	Carrier's name and address
0110		SG2	R	1	1	Ship from
0120	14	NAD	M	1	1	Ship From's Name and address
0110		SG2	D	1	1	Delivery Party
0120	15	NAD	M	1	1	Delivery Party's Name and Address
0200		SG5	D	1	1	Terms of delivery
0210	16	TOD	M	1	1	Terms of delivery or transport
0240		SG6	D	1	1	Means of transport
0250	17	TDT	M	1	1	Transport information
0310		SG8	D	1	1	Container details
0320	18	EQD	M	1	1	Container identification
0310		SG8	D	1	1	Trailer details
0320	19	EQD	M	1	1	Trailer identification
0390		SG10	R	9999	1	Despatch control line / group of inner packaging items and article line
0400	20	CPS	M	1	1	Consignment packing sequence
0430		SG11	R	9999	2	Group of inner packaging items
0440	21	PAC	M	1	2	Package
0460	22	QTY	R	1	3	Actual quantity per package
0500		SG13	R	1000	3	Individual packaging item
0510	23	PCI	M	1	3	Package identification

Counter = Counter of segment/group within the standard
 No = Consecutive segment number
 MaxOcc = Maximum occurrence of the segment/group

St = Status
 EDIFACT: M=Mandatory, C=Conditional
 User specific: R=Required, O=Optional, D=Dependent,
 A=Advised, N=Not used

Counter	No	Tag	St	MaxOcc	Level	Content	
	0520	24	RFF	D	1	4	Reference to outer package
	0540		SG14	D	1	4	Production batch
	0550	25	GIR	M	1	4	Trigger segment
	0570		SG15	R	99	4	Label number(s)
	0580	26	GIN	M	1	4	Label serial number(s)
	0570		SG15	D	99	4	Kanban card number
	0580	27	GIN	M	1	4	Kanban card number
	0650		SG17	R	1	2	Article and Despatched Article
	0660	28	LIN	M	1	2	Line item
	0670	29	PIA	D	1	3	Additional product id
	0700	30	QTY	R	1	3	Despatched quantity
	0710	31	ALI	R	1	3	Additional information
	0720	32	GIN	D	100	3	Serial Number(s)/Engine Number(s)/Vehicle Identity Number(s)
	0810	33	MOA	D	1	3	Customs declared value
	0830		SG18	R	1	3	Order reference
	0840	34	RFF	M	1	3	Order reference
	0830		SG18	D	1	3	Invoice reference
	0840	35	RFF	M	1	3	Invoice reference
	0870	36	DTM	D	1	4	Date/time/period
	0830		SG18	D	1	3	Part consignment number reference
	0840	37	RFF	M	1	3	Reference
	0830		SG18	D	99	3	Module Reference Number
	0840	38	RFF	M	1	3	Reference
	0920		SG20	R	1	3	Internal place of destination
	0930	39	LOC	M	1	3	Place/location identification
	1160	40	UNT	M	1	0	Message trailer

Counter = Counter of segment/group within the standard
 No = Consecutive segment number
 MaxOcc = Maximum occurrence of the segment/group

St = Status
 EDIFACT: M=Mandatory, C=Conditional
 User specific: R=Required, O=Optional, D=Dependent,
 A=Advised, N=Not used

Branching Diagram of Used Segments/Groups

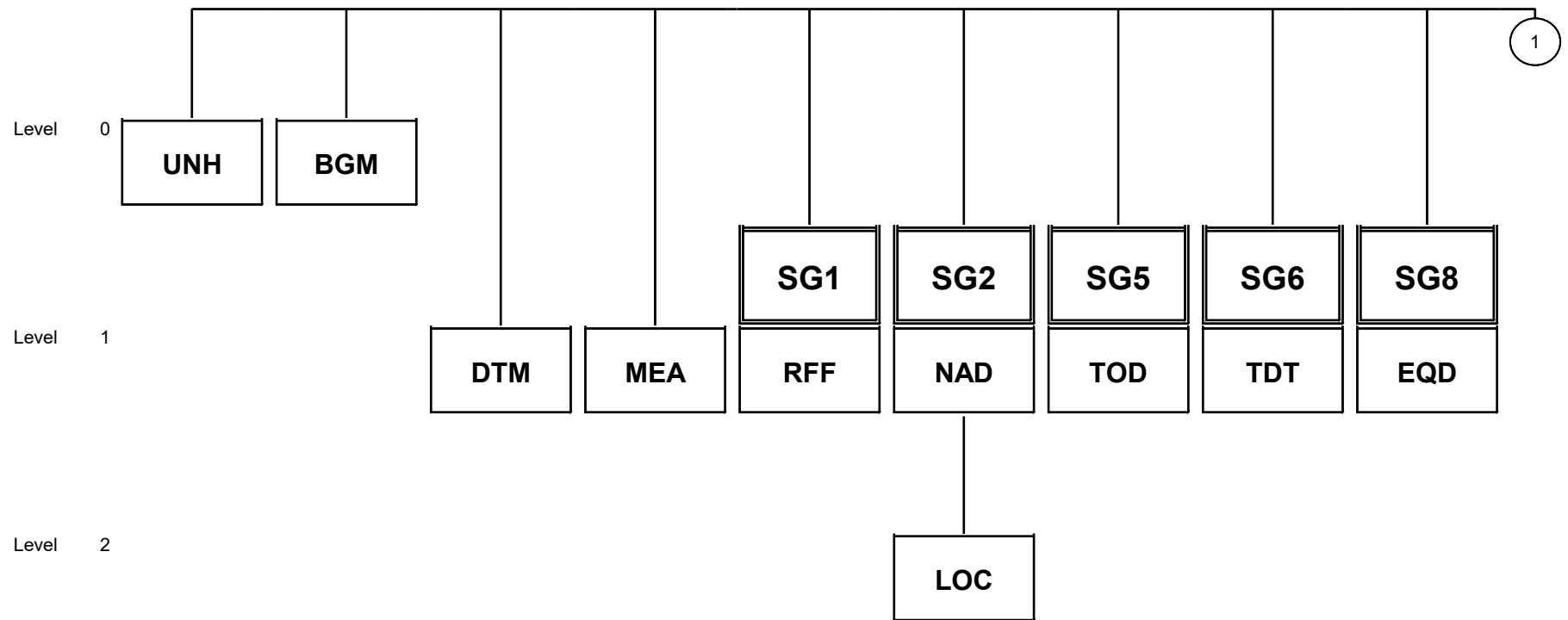

VOLVO GLOBAL DESADV D07A

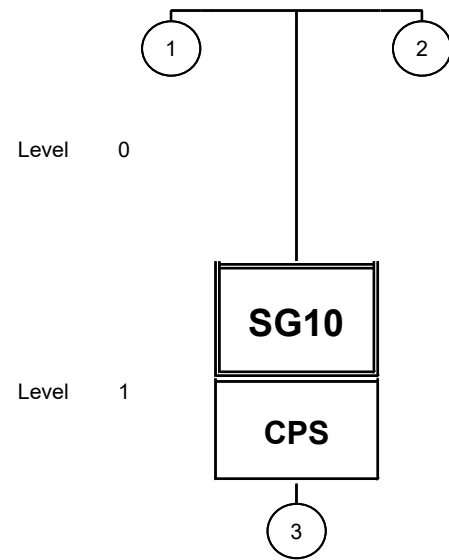

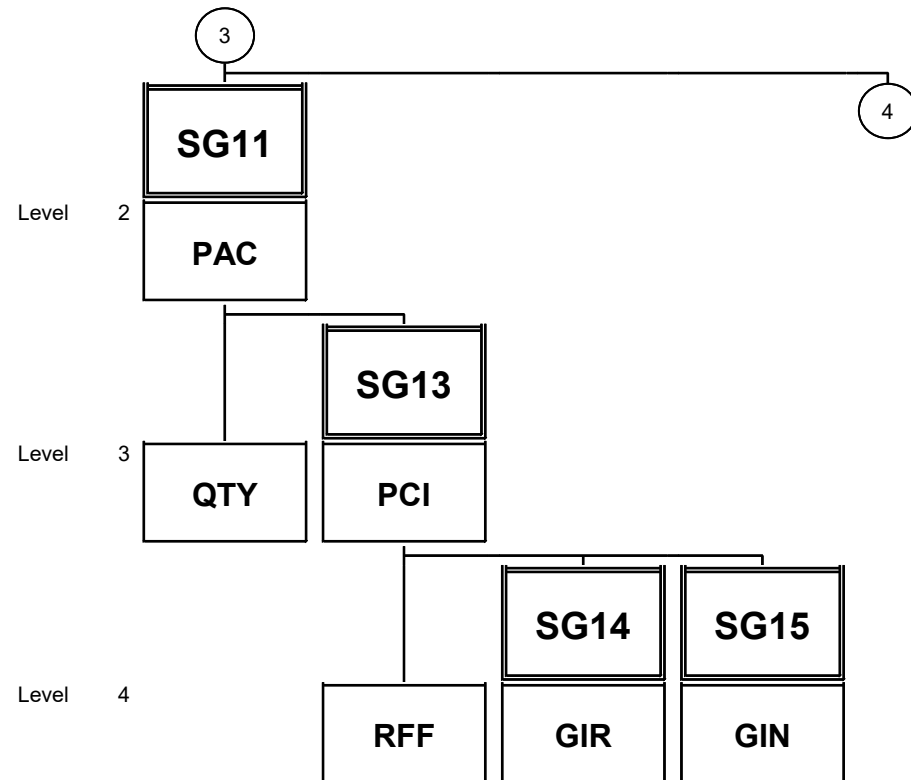

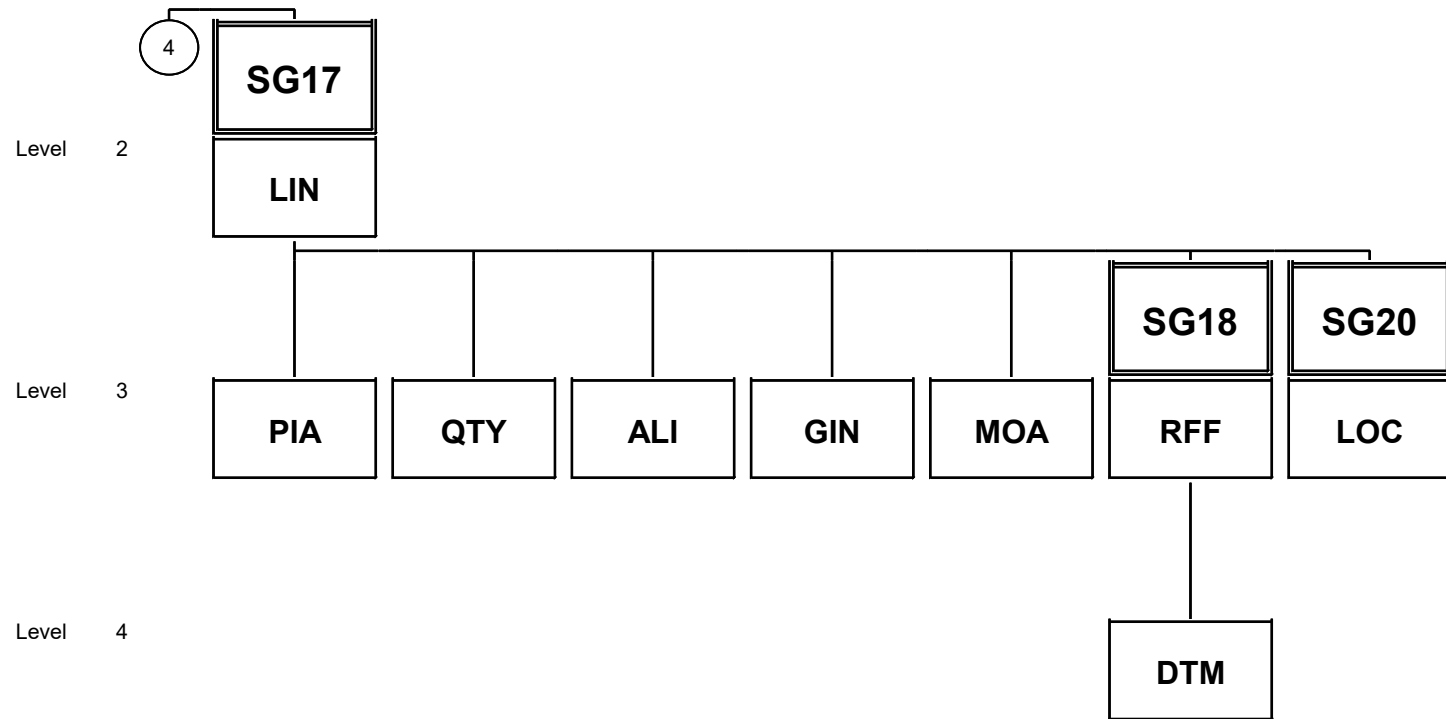

VOLVO GLOBAL DESADV D07A

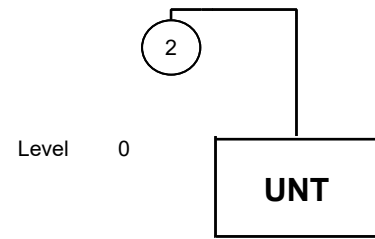

VOLVO GLOBAL DESADV D07A

Segment details

Segment:

UNH

Seq. No.: 1 Level: 0
 Status: M Max. Occ.: 1
 Counter: 0010

Message header

Name: Message header

Description of segment:

UN/EDIFACT			Implementation	
	Name	St Format	St Format	Use / Remarks
UNH 0062	Message reference number	M an..14	M an..14	Message reference number - unique number to identify the message within the interchange, usually a consecutive number starting with 1.
S009	Message identifier	M	M	
0065	Message type	M an..6	M an..6	DESADV Despatch advice message
0052	Message version number	M an..3	M an..3	D Draft version/UN/EDIFACT Directory
0054	Message release number	M an..3	M an..3	07A Release 2007 - A
0051	Controlling agency	M an..2	M an..2	UN UN/CEFACT
0057	Association assigned code	C an..6	R an..6	Identification of the subset release, assigned by the responsible organisation (Odette resp. joint automotive initiative forum). GBSG11 Volvo Group DESADV D07A Batch (2014 version)

Remark:

Example:

UNH+1+DESADV:D:07A:UN:GBSG11'

VOLVO GLOBAL DESADV D07A

Segment details

Segment: BGM
 Seq. No.: 2 Level: 0 **Beginning of message**
 Status: M Max. Occ.: 1
 Counter: 0020

Name: Beginning of message

Description of segment:

UN/EDIFACT			Implementation	
	Name	St Format	St Format	Use / Remarks
BGM				
C002	Document/message name	C	R	
1001	Document name code	C an..3	R an..3	351 Despatch advice
C106	Document/message identification	C	R	
1004	Document identifier	C an..35	R an..16	Unique number for the Despatch Advice. The number must correspond with the Despatch Note Number. The number must not be repeated within one year. The field length is restricted to "an..8", when Odette Transport Label (OTL) version 1.4 and 3.1 is used in the shipment. The length and value must correspond between the OTL and the DESADV.

Remark:

The Despatch Advice Number in BGM.1004 shall also be given on the Transport label.

Example:

BGM+351+465832'

VOLVO GLOBAL DESADV D07A

Segment details

Segment: DTM
 Seq. No.: 3 Level: 1 **Date/time/period**
 Status: R Max. Occ.: 1
 Counter: 0030

Name: Despatch advice date

Description of segment:

UN/EDIFACT			Implementation	
	Name	St Format	St Format	Use / Remarks
DTM				
C507	Date/time/period	M	M	
2005	Date or time or period function code qualifier	M an..3	M an..3	137 Document/message date/time
2380	Date or time or period text	C an..35	R n12	Date and time on which the message was created.
2379	Date or time or period format code	C an..3	R an..3	203 CCYYMMDDHHMM

Remark:

Example:

DTM+137:200604011000:203'

VOLVO GLOBAL DESADV D07A

Segment details

Segment:

MEA

Seq. No.: 4 Level: 1
 Status: D Max. Occ.: 1
 Counter: 0050

Measurements

Name: Consignment's gross weight

Description of segment:

UN/EDIFACT			Implementation	
	Name	St Format	St Format	Use / Remarks
MEA				
6311	Measurement purpose code qualifier	M an..3	M an..3	AAX Consignment measurement
C502	Measurement details	C	R	
6313	Measured attribute code	C an..3	R an..3	AAD Total gross weight
C174	Value/range	C	R	
6411	Measurement unit code	M an..8	M an..3	KGM Kilogram LBR Pound
6314	Measure	C an..18	R n..12	Gross weight. Maximum 3 decimals.

Remark:

Total consignment gross weight - weight including inner and outer packaging.
 Should always be given when Volvo Group is managing the import customs clearance. Not required if the supplier is responsible for the import customs clearance.

Example:

MEA+AAX+AAD+KGM:1000'

VOLVO GLOBAL DESADV D07A

Segment details

Segment:

MEA

Seq. No.: 5 Level: 1
 Status: D Max. Occ.: 1
 Counter: 0050

Measurements

Name: Consignment volume (Total cube)

Description of segment:

UN/EDIFACT			Implementation	
	Name	St Format	St Format	Use / Remarks
MEA				
6311	Measurement purpose code qualifier	M an..3	M an..3	AAX Consignment measurement
C502	Measurement details	C	R	
6313	Measured attribute code	C an..3	R an..3	ABJ Volume
C174	Value/range	C	R	
6411	Measurement unit code	M an..8	M an..3	MTQ Cubic metre
6314	Measure	C an..18	R n..9	Volume measure. Maximum 3 decimals.

Remark:

Total cube of all goods items referred to as one despatch.
 Should always be given when Volvo Group is managing the import customs clearance. Not required if the supplier is responsible for the import customs clearance.

Example:

MEA+AAX+ABJ+MTQ; 4 '

VOLVO GLOBAL DESADV D07A

Segment details

Group: **SG1** Status: R Max. Occ.: 1 Transport document reference

Segment: **RFF** Seq. No.: 6 Level: 1 **Reference**
 Status: M Max. Occ.: 1
 Counter: 0090

Name: **Transport document reference**

Description of segment:

UN/EDIFACT			Implementation	
	Name	St Format	St Format	Use / Remarks
RFF				
C506	Reference	M	M	
1153	Reference code qualifier	M an..3	M an..3	AAS Transport document number
1154	Reference identifier	C an..70	R an..70	Reference number

Remark:

The identification number on the Transport Booking Request or the transport document, valid between Consignor/Supplier, Carrier and Volvo.

Primary rule:

When using Volvo ShiplT system to generate the Transport Booking Request, the TBR ID should always be the reference given in RFF.1154.

In other cases:

If Volvo ShiplT system is not used the REF.1154 shall contain a reference to the transport document number (Carrier's Reference Number: Pro Number, Tracking Number, Air waybill number, Bill of lading number). In addition the NAD+CA, TDT and TOD segments shall be given.

Note:

The reference number must be clearly shown on the Transport document and be identical to the number given in SG1.RFF.1154.

For more information; see the Transport Instructions provided by concerned Volvo business unit.

Example:

RFF+AAS:S00453805100701'

VOLVO GLOBAL DESADV D07A

Segment details

Group: **SG1** Status: D Max. Occ.: 1 Customer reference number

Segment: **RFF** Seq. No.: 7 Level: 1 **Reference**
 Status: M Max. Occ.: 1
 Counter: 0090

Name: **Customer Reference Number**

Description of segment:

UN/EDIFACT			Implementation	
	Name	St Format	St Format	Use / Remarks
RFF				
C506	Reference	M	M	
1153	Reference code qualifier	M an..3	M an..3	CR Customer reference number
1154	Reference identifier	C an..70	R an..70	Reference number

Remark:

This segment should only be used after special agreement.

Example:

RFF+CR:74'

VOLVO GLOBAL DESADV D07A

Segment details

Group: **SG2** Status: R Max. Occ.: 1 ShipTo

Segment: **NAD** Seq. No.: 8 Level: 1 **Name and address**
 Status: M Max. Occ.: 1
 Counter: 0120

Name: **ShipTo's name and address**

Description of segment:

UN/EDIFACT			Implementation	
	Name	St Format	St Format	Use / Remarks
NAD				
3035	Party function code qualifier	M an..3	M an..3	ST Ship to
C082	Party identification details	C	R	
3039	Party identifier	M an..35	M an..20	Ship-To ID. Volvo's identity of the Ship-To.
1131	Code list identification code	C an..17	N	not used
3055	Code list responsible agency code	C an..3	R an..3	92 Assigned by buyer or buyer's agent
C058	Name and address	C	N	not used
3124	Name and address description	M an..35	N	not used
C080	Party name	C	D	
3036	Party name	M an..35	M an..35	Single text line for specification of a name.
C059	Street	C	D	
3042	Street and number or post office box identifier	M an..35	M an..35	The name that identifies the location of a house or building; usually within a street as part of an address.
3042	Street and number or post office box identifier	C an..35	C an..35	
3164	City name	C an..35	D an..35	The name of the city, town, or village of this address.
C819	Country subdivision details	C	D	
3229	Country subdivision identifier	C an..9	R an..9	State or region within a country. The use of UN LoCodes is recommended.
1131	Code list identification code	C an..17	N	not used
3251	Postal identification code	C an..17	D an..17	Postal code/Zip code
3207	Country identifier	C an..3	D an..3	Provides the country part of an address using a code. Use ISO3166 two alpha code.

Remark:

The party to which goods are to be shipped (consigned).
 Name and address information to be used in agreement between concerned parties.

Example:

NAD+ST+4388::92++VOLVO TRUCKS NORTH AMERICA LLC+4881 COUGAR TRAIL
 ROAD+DUBLIN+VA+24084+AD'

VOLVO GLOBAL DESADV D07A

Segment details

Group: **SG2** Status: R Max. Occ.: 1 ShipTo

Segment: **LOC** Seq. No.: 9 Level: 2 **Place/location identification**
 Status: R Max. Occ.: 1
 Counter: 0130

Name: **Place of discharge**

Description of segment:

UN/EDIFACT			Implementation	
	Name	St Format	St Format	Use / Remarks
LOC				
3227	Location function code qualifier	M an..3	M an..3	11 Place/port of discharge
C517	Location identification	C	R	
3225	Location identifier	C an..35	R an..35	Volvo's identity on Place of Discharge
1131	Code list identification code	C an..17	N	not used
3055	Code list responsible agency code	C an..3	R an..3	92 Assigned by buyer or buyer's agent

Remark:

Example:

LOC+11+556:::92'

VOLVO GLOBAL DESADV D07A

Segment details

Group: **SG2** Status: D Max. Occ.: 1 Buyer

Segment: **NAD** Seq. No.: 10 Level: 1 **Name and address**
 Status: M Max. Occ.: 1
 Counter: 0120

Name: **Buyer's name and address**

Description of segment:

UN/EDIFACT			Implementation	
	Name	St Format	St Format	Use / Remarks
NAD				
3035	Party function code qualifier	M an..3	M an..3	BY Buyer
C082	Party identification details	C	R	
3039	Party identifier	M an..35	M an..35	Buyer ID.
1131	Code list identification code	C an..17	N	not used
3055	Code list responsible agency code	C an..3	R an..3	92 Assigned by buyer or buyer's agent
C058	Name and address	C	N	not used
3124	Name and address description	M an..35	N	not used
C080	Party name	C	D	
3036	Party name	M an..35	M an..35	Single text line for specification of a name.
C059	Street	C	D	
3042	Street and number or post office box identifier	M an..35	M an..35	The name that identifies the location of a house or building; usually within a street as part of an address.
3042	Street and number or post office box identifier	C an..35	C an..35	
3164	City name	C an..35	D an..35	The name of the city, town, or village of this address.
C819	Country subdivision details	C	D	
3229	Country subdivision identifier	C an..9	R an..9	State or region within a country. The use of UN LoCodes is recommended.
3251	Postal identification code	C an..17	D an..17	Postal code/Zip code
3207	Country identifier	C an..3	D an..3	Provides the country part of an address using a code. Use ISO3166 two alpha code.

Remark:

Name and address information to be used in agreement between concerned parties.

Example:

NAD+BY+1020::92++VOLVO LASTVAGNAR AB+TUVE+GÖTEBORG++40508+SE'

VOLVO GLOBAL DESADV D07A

Segment details

Group: **SG2** Status: D Max. Occ.: 1 Ultimate Customer

Segment: **NAD** Seq. No.: 11 Level: 1 **Name and address**
 Status: M Max. Occ.: 1
 Counter: 0120

Name: **Ultimate customers's name and address**

Description of segment:

UN/EDIFACT			Implementation	
	Name	St Format	St Format	Use / Remarks
NAD				
3035	Party function code qualifier	M an..3	M an..3	UD Ultimate Customer
C082	Party identification details	C	R	
3039	Party identifier	M an..35	M an..20	Ultimate Customer ID.
1131	Code list identification code	C an..17	N	not used
3055	Code list responsible agency code	C an..3	R an..3	92 Assigned by buyer or buyer's agent
C058	Name and address	C	N	not used
3124	Name and address description	M an..35	N	not used
C080	Party name	C	D	
3036	Party name	M an..35	M an..35	Single text line for specification of a name.
C059	Street	C	D	
3042	Street and number or post office box identifier	M an..35	M an..35	The name that identifies the location of a house or building; usually within a street as part of an address.
3042	Street and number or post office box identifier	C an..35	C an..35	
3164	City name	C an..35	D an..35	The name of the city, town, or village of this address.
C819	Country subdivision details	C	D	
3229	Country subdivision identifier	C an..9	R an..9	State or region within a country. The use of UN LoCodes is recommended.
3251	Postal identification code	C an..17	D an..17	Postal code/Zip code
3207	Country identifier	C an..3	D an..3	Provides the country part of an address using a code. Use ISO3166 two alpha code.

Remark:

The ultimate customer is the final recipient of the goods.
 Name and address information to be used in agreement between concerned parties.

Example:

NAD+UD+1001::92++VOLVO LASTVAGNAR AB+TUVE+GÖTEBORG++40508+SE'

VOLVO GLOBAL DESADV D07A

Segment details

Group: **SG2** Status: D Max. Occ.: 1 Seller

This segment group is required when Ship From and Seller have been allocated different identities by the Buyer.

Segment: **NAD** Seq. No.: 12 Level: 1 **Name and address**
 Status: M Max. Occ.: 1
 Counter: 0120

Name: **Seller's name and address**

Description of segment:

UN/EDIFACT			Implementation	
	Name	St Format	St Format	Use / Remarks
NAD				
3035	Party function code qualifier	M an..3	M an..3	SE Seller
C082	Party identification details	C	R	
3039	Party identifier	M an..35	M an..35	Seller ID.
1131	Code list identification code	C an..17	N	not used
3055	Code list responsible agency code	C an..3	R an..3	92 Assigned by buyer or buyer's agent
C058	Name and address	C	N	not used
3124	Name and address description	M an..35	N	not used
C080	Party name	C	D	
3036	Party name	M an..35	M an..35	Single text line for specification of a name.
C059	Street	C	D	
3042	Street and number or post office box identifier	M an..35	M an..35	The name that identifies the location of a house or building; usually within a street as part of an address.
3042	Street and number or post office box identifier	C an..35	C an..35	
3164	City name	C an..35	D an..35	The name of the city, town, or village of this address.
C819	Country subdivision details	C	D	
3229	Country subdivision identifier	C an..9	R an..9	State or region within a country. The use of UN LoCodes is recommended.
3251	Postal identification code	C an..17	D an..17	Postal code/Zip code
3207	Country identifier	C an..3	D an..3	Provides the country part of an address using a code. Use ISO3166 two alpha code.

Remark:

Name and address information to be used in agreement between concerned parties.

Example:

NAD+SE+11122::92++SELLER COMPANY+SELLERROAD+SELLERTOWN++DE5409+DE'

VOLVO GLOBAL DESADV D07A

Segment details

Group: **SG5** Status: D Max. Occ.: 1 Terms of delivery

Segment: **TOD** Seq. No.: 16 Level: 1 **Terms of delivery or transport**
 Status: M Max. Occ.: 1
 Counter: 0210

Name: **Terms of delivery or transport**

Description of segment:

UN/EDIFACT			Implementation		
	Name	St Format	St Format	Use / Remarks	
TOD					
4055	Delivery or transport terms function code	C an..3	N	not used	
4215	Transport charges payment method code	C an..3	N	not used	
C100	Terms of delivery or transport	C	R		
4053	Delivery or transport terms description code	C an..3	R an..3	CFR Cost and Freight CIF Cost, Insurance, Freight CIP Carriage and Insurance Paid to CPT Carriage Paid To DAP Delivered at Place DAT Delivered at Terminal DDP Delivered Duty Paid EXW Ex Works FAS Free Along Ship FCA Free Carrier FOB Free On Board	
1131	Code list identification code	C an..17	N	not used	
3055	Code list responsible agency code	C an..3	O an..3	4	ICC (International Chamber of Commerce)

Remark:

The delivery terms valid for the concerned despatch or consignment.
 If a ShipIT TBR has been provided in RFF+AAS, then TOD segment is not required.
 If a ShipIT TBR has not been given as the transport document number in RFF+AAS, then the TOD segment is required.

Example:

TOD+++FOB'

VOLVO GLOBAL DESADV D07A

Segment details

Group: **SG6** Status: D Max. Occ.: 1 Means of transport

Segment: **TDT** Seq. No.: 17 Level: 1 **Transport information**
 Status: M Max. Occ.: 1
 Counter: 0250

Name: **Transport information**

Description of segment:

UN/EDIFACT			Implementation	
	Name	St Format	St Format	Use / Remarks
TDT				
8051	Transport stage code qualifier	M an..3	M an..3	12 At departure
8028	Means of transport journey identifier	C an..17	N	not used
C220	Mode of transport	C	O	
8067	Transport mode name code	C an..3	R an..3	10 Maritime transport 20 Rail transport 30 Road transport 40 Air transport 50 Mail 60 Multimodal transport
C001	Transport means	C	N	not used
8179	Transport means description code	C an..8	N	not used
C040	Carrier	C	N	not used
3127	Carrier identifier	C an..17	N	not used
8101	Transit direction indicator code	C an..3	N	not used
C401	Excess transportation information	C	N	not used
8457	Excess transportation reason code	M an..3	N	not used
C222	Transport identification	C	R	
8213	Transport means identification name identifier	C an..35	R an..35	Identifier of a means of transport, like license plate etc.

Remark:

If a ShipIT TBR has been provided in RFF+AAS, then TDT segment is not required.
 If a ShipIT TBR has not been given as the transport document number in RFF+AAS, then the TDT segment is required.

Example:

TDT+12++30+++++HPG324'

VOLVO GLOBAL DESADV D07A

Segment details

Group: **SG8** Status: D Max. Occ.: 1 Container details
 Used if container information is required.

Segment: **EQD** Seq. No.: 18 Level: 1 **Equipment details**
 Status: M Max. Occ.: 1
 Counter: 0320

Name: **Container identification**

Description of segment:

UN/EDIFACT			Implementation	
	Name	St Format	St Format	Use / Remarks
EQD				
8053	Equipment type code qualifier	M an..3	M an..3	CN Container Code qualifying the type of an equipment.
C237	Equipment identification	C	R	
8260	Equipment identifier	C an..17	R an..17	Identifier of the container used.

Remark:
 Information identifying and describing the equipment used.

Example:
 EQD+CN+VOEU2127403'

VOLVO GLOBAL DESADV D07A

Segment details

Group: **SG8** Status: D Max. Occ.: 1 Trailer details
 Used if trailer information is required.

Segment: **EQD** Seq. No.: 19 Level: 1 **Equipment details**
 Status: M Max. Occ.: 1
 Counter: 0320

Name: **Trailer identification**

Description of segment:

UN/EDIFACT			Implementation	
	Name	St Format	St Format	Use / Remarks
EQD				
8053	Equipment type code qualifier	M an..3	M an..3	TE Trailer Code qualifying the type of an equipment.
C237	Equipment identification	C	R	
8260	Equipment identifier	C an..17	R an..17	Identifier of an equipment used.

Remark:
 Information identifying and describing the equipment used.

Example:
 EQD+TE+TR494645'

VOLVO GLOBAL DESADV D07A

Segment details

Group: **SG10** Status: R Max. Occ.: 9999 Despatch control line / group of inner packaging items and article line

- This segment group shall be repeated for each:
- part number ID (SG17 LIN)
 - unique Additional internal destination (LOC+159)
 - unique Order number (RFF+ON)
 - unique Part consignment number (RFF+AAP)

Segment: **CPS** Seq. No.: 20 Level: 1 **Consignment packing sequence**
 Status: M Max. Occ.: 1
 Counter: 0400

Name: **Consignment packing sequence**

Description of segment:

UN/EDIFACT			Implementation	
	Name	St Format	St Format	Use / Remarks
CPS				
7164	Hierarchical structure level identifier	M an..35	M n..6	Line Number The line number value must not be duplicated within the same message (UNH-UNT).
7166	Hierarchical structure parent identifier	C an..35	N	not used
7075	Packaging level code	C an..3	R an..3	1 Inner

Remark:
 Sequential number generated by the sender to identify a line item within a message.

Example:
 CPS+1++1 '

VOLVO GLOBAL DESADV D07A

Segment details

Group: **SG10** Status: R Max. Occ.: 9999 Despatch control line / group of inner packaging items and article line

Group: **SG11** Status: R Max. Occ.: 9999 Group of inner packaging items

Group: **SG13** Status: R Max. Occ.: 1000 Individual packaging item

This segment group shall be repeated when one article number is packed into more than one handling unit or if the part number derives from different production batches(provided in GIR.7402).

Segment: **PCI** Seq. No.: 23 Level: 3 **Package identification**
 Status: M Max. Occ.: 1
 Counter: 0510

Name: Package identification

Description of segment:

UN/EDIFACT			Implementation	
	Name	St Format	St Format	Use / Remarks
PCI				
4233	Marking instructions code	C an..3	N	not used
C210	Marks & labels	C	N	not used
7102	Shipping marks description	M an..35	N	not used
8169	Full or empty indicator code	C an..3	N	not used
C827	Type of marking	C	R	
7511	Marking type code	M an..3	M an..3	Handling Unit Category G Mixed handling unit M Homogeneous handling unit S Simplified handling unit / Inner package 1J, 5J, and 6J shall be used when license plate is required. 1J Unique license plate number lowest package level (unbreakable unit). Simplified handling unit 5J Unique license plate number mixed load. Mixed handling unit. 6J Unique license plate number assigned to a master load. Homogeneous handling unit. To be used according to Volvo's transport label specification and/or packaging instructions.
1131	Code list identification code	C an..17	N	not used
3055	Code list responsible agency code	C an..3	R an..3	10 ODETTE Used for G, M, S 5 ISO (International Organization for Standardization) Used for 1J, 5J, 6J

Remark:

Information in 7511 should correspond with the serial number barcode qualifier on the transport label. For more information regarding the usage of Handling Unit Category see Volvo group "DESADV D07A Impl Guideline" document.

Example:

PCI++++G::10'
 PCI++++1J::5'

VOLVO GLOBAL DESADV D07A

Segment details

Group: **SG10** Status: R Max. Occ.: 9999 Despatch control line / group of inner packaging items and article line

Group: **SG11** Status: R Max. Occ.: 9999 Group of inner packaging items

Group: **SG13** Status: R Max. Occ.: 1000 Individual packaging item

Group: **SG15** Status: R Max. Occ.: 99 Label number(s)

The total number of SG15 in a SG13 shall not exceed 99.

Segment: **GIN** Seq. No.: 26 Level: 4 **Goods identity number**
 Status: M Max. Occ.: 1
 Counter: 0580

Name: Label serial number(s)

Description of segment:

UN/EDIFACT			Implementation	
	Name	St Format	St Format	Use / Remarks
GIN				
7405	Object identification code qualifier	M an..3	M an..3	ML Marking/label number Identity Number Type
C208	Identity number range	M	M	
7402	Object identifier	M an..35	R an..20	Identity Number (Package Label Number) The field format is restricted to "n..9" when Odette Transport Label (OTL) version 1.4 or 3.1 is used. The length and value must correspond between the OTL and the DESADV.
C208	Identity number range	C	D	
7402	Object identifier	M an..35	R an..20	Identity Number (Package Label Number) The field format is restricted to "n..9" when Odette Transport Label (OTL) version 1.4 or 3.1 is used. The length and value must correspond between the OTL and the DESADV.
C208	Identity number range	C	D	
7402	Object identifier	M an..35	R an..20	Identity Number (Package Label Number) The field format is restricted to "n..9" when Odette Transport Label (OTL) version 1.4 or 3.1 is used. The length and value must correspond between the OTL and the DESADV.
C208	Identity number range	C	D	
7402	Object identifier	M an..35	R an..20	Identity Number (Package Label Number) The field format is restricted to "n..9" when Odette Transport Label (OTL) version 1.4 or 3.1 is used. The length and value must correspond between the OTL and the DESADV.

Remark:

Package label number or ID of an individual package or handling unit (PCI.7511:S). Not to be repeated within 365 rolling days.

Example:

GIN+ML+20056789+20056790+20056791+20056792+20056793 '

VOLVO GLOBAL DESADV D07A

Segment details

Group: **SG10** Status: R Max. Occ.: 9999 Despatch control line / group of inner packaging items and article line

Group: **SG17** Status: R Max. Occ.: 1 Article and Despatched Article

Segment: **PIA** Seq. No.: 29 Level: 3 **Additional product id**
 Status: D Max. Occ.: 1
 Counter: 0670

Name: **Additional product id**

Description of segment:

UN/EDIFACT			Implementation	
	Name	St Format	St Format	Use / Remarks
PIA				
4347	Product identifier code qualifier	M an..3	R an..3	1 Additional identification
C212	Item number identification	M	M	
7140	Item identifier	C an..35	R an..35	Drawing revision number.
7143	Item type identification code	C an..3	R an..3	DR Drawing revision number

Remark:

Drawing revision number should always be sent, once received in delivery schedule.

Example:

PIA+1+P04:DR'

VOLVO GLOBAL DESADV D07A

Segment details

Group: **SG10** Status: R Max. Occ.: 9999 Despatch control line / group of inner packaging items and article line

Group: **SG17** Status: R Max. Occ.: 1 Article and Despatched Article

Segment: **QTY** Seq. No.: 30 Level: 3 **Quantity**
 Status: R Max. Occ.: 1
 Counter: 0700

Name: Despatched quantity

Description of segment:

UN/EDIFACT			Implementation	
	Name	St Format	St Format	Use / Remarks
QTY				
C186	Quantity details	M	M	
6063	Quantity type code qualifier	M an..3	M an..3	12 Despatch quantity
6060	Quantity	M an..35	M n..10	Quantity actually despatched
6411	Measurement unit code	C an..8	D an..3	Code specifying the unit of measurement. Use the Measurement unit code given in the Order. Recommend use UN/ECE Recommendation 20, Common code. If left blank, the value will be considered as C62 (one unit).

Remark:

Example:

QTY+12:300:C62'

VOLVO GLOBAL DESADV D07A

Segment details

Group: **SG10** Status: R Max. Occ.: 9999 Despatch control line / group of inner packaging items and article line

Group: **SG17** Status: R Max. Occ.: 1 Article and Despatched Article

Segment: **ALI** Seq. No.: 31 Level: 3 **Additional information**
 Status: R Max. Occ.: 1
 Counter: 0710

Name: **Additional information**

Description of segment:

UN/EDIFACT			Implementation	
	Name	St Format	St Format	Use / Remarks
ALI 3239	Country of origin identifier	C an..3	R a2	Country Of Origin code. Identification of the name of the country or other geographical entity as defined in ISO 3166-1. Use ISO 3166-1 two alpha country code.

Remark:

Country in which goods have been produced or manufactured, according to criteria laid down for the purposes of application of the customs tariff, quantitative restrictions, etc.

Example:

ALI+US'

VOLVO GLOBAL DESADV D07A

Segment details

Group: **SG10** Status: R Max. Occ.: 9999 Despatch control line / group of inner packaging items and article line

Group: **SG17** Status: R Max. Occ.: 1 Article and Despatched Article

Segment: **GIN** Seq. No.: 32 Level: 3 **Goods identity number**
 Status: D Max. Occ.: 100
 Counter: 0720

Name: **Serial Number(s)/Engine Number(s)/Vehicle Identity Number(s)**

Description of segment:

UN/EDIFACT			Implementation	
	Name	St Format	St Format	Use / Remarks
GIN 7405	Object identification code qualifier	M an..3	M an..3	Identity Number Type BN Serial number EE Engine number VV Vehicle identity number
C208	Identity number range	M	M	
7402	Object identifier	M an..35	M an..35	Identity Number
C208	Identity number range	C	D	Further identity number
7402	Object identifier	M an..35	M an..35	Identity Number
C208	Identity number range	C	D	Further identity number
7402	Object identifier	M an..35	M an..35	Identity Number
C208	Identity number range	C	D	Further identity number
7402	Object identifier	M an..35	M an..35	Identity Number
C208	Identity number range	C	D	Further identity number
7402	Object identifier	M an..35	M an..35	Identity Number

Remark:

The segment is used to give information about the serial number, engine number or vehicle identity number for those components which are identified as individual units.

If more than one identity should be given; use the first five appearances of C208 before you repeat the segment.

Example:

GIN+BN+1234+2345+3456+4567+5678'

GIN+EE+1234+2345+3456+4567+5678'

GIN+VV+1234+2345+3456+4567+5678'

VOLVO GLOBAL DESADV D07A

Segment details

Group: **SG10** Status: R Max. Occ.: 9999 Despatch control line / group of inner packaging items and article line

Group: **SG17** Status: R Max. Occ.: 1 Article and Despatched Article

Group: **SG18** Status: D Max. Occ.: 99 Module Reference Number
 This SG18 should only be used for JIT/JIS Flows.

Segment: **RFF** Seq. No.: 38 Level: 3 **Reference**
 Status: M Max. Occ.: 1
 Counter: 0840

Name: Reference

Description of segment:

UN/EDIFACT		Implementation		
	Name	St Format	St Format	Use / Remarks
RFF				
C506	Reference	M	M	
1153	Reference code qualifier	M an..3	M an..3	CR Customer reference number
1154	Reference identifier	C an..70	R an..70	Customer reference number.

Remark:

Use this segment to reference a specific module number (given by the customer).
 For Volvo CE KANBAN flow the DELJIT BGM.1004 value should be given.

Example:

RFF+CR:234567'

VOLVO GLOBAL DESADV D07A

Segment details

Group:	SG10	Status: R	Max. Occ.: 9999	Despatch control line / group of inner packaging items and article line
Group:	SG17	Status: R	Max. Occ.: 1	Article and Despatched Article
Group:	SG20	Status: R	Max. Occ.: 1	Internal place of destination
Segment:	LOC	Seq. No.: 39 Status: M Counter: 0930	Level: 3 Max. Occ.: 1	Place/location identification

Name: Place/location identification

Description of segment:

UN/EDIFACT		Implementation		
	Name	St Format	St Format	Use / Remarks
LOC				
3227	Location function code qualifier	M an..3	M an..3	159 Additional internal destination
C517	Location identification	C	R	
3225	Location identifier	C an..35	R an..35	Final unloading point. To be obtained from the DELFOR/DELJIT message.
1131	Code list identification code	C an..17	N	not used
3055	Code list responsible agency code	C an..3	R an..3	92 Assigned by buyer or buyer's agent

Remark:

An internal location within the ship-to's premises where goods are moved to after they have been unloaded, e.g. an assembly line, an internal warehouse, etc.

Example:

LOC+159+V11-A5-01::92'

VOLVO GLOBAL DESADV D07A

Segment details

Segment:

UNT

Seq. No.: 40 Level: 0
 Status: M Max. Occ.: 1
 Counter: 1160

Message trailer

Name: **Message trailer**

Description of segment:

UN/EDIFACT			Implementation	
	Name	St Format	St Format	Use / Remarks
UNT 0074	Number of segments in the message	M n..6	M n..6	Number of segments in the message
0062	Message reference number	M an..14	M an..14	Message reference number

Remark:

Example:

UNT+187+1'