

VOLVO'S GLOBAL DELIVERY FORECAST MESSAGE
Implementation Guidelines



GLOBAL DELIVERY FORECAST MESSAGE

Volvo's Implementation Guidelines
(DELFOR)
Version 1;Revision 1

VOLVO'S GLOBAL DELIVERY FORECAST MESSAGE Implementation Guidelines
--

General

Global DELFOR specifications

The specifications regarding Global DELFOR could be obtained from the Internet:

- The Joint Automotive Industries (JAI) Global DELFOR. Based on EDIFACT Directory, D04A. – [Odette International Homepage](#)
- The Swedish Odette subset of Global DELFOR - www.odette.se.
- The Volvo profile of the Global DELFOR – www.volvo.com/edi_europe (click specifications).

Description of changes between version 1.1 and 1.0 of Volvo's Global DELFOR

SG7 NAD ST C059 and 3164 changed from Dependent to Optional.

SG10 has changed from Dependent to Optional.

SG12 PIA Vendor item number added. Used by some Volvo group plants/warehouses only.

SG12 IMD has changed from Dependent to Optional.

Description of differences between Volvo's Global DELFOR and the current Volvo EDIFACT message (v4)

- Code 236 = Delivery forecast, is added in BGM-segment
- The Buyer code, NAD 3039, will be assigned by the buyer instead of the Seller. Volvo will here give the identification of the buying company, which also shall be given by the Seller in the INVOIC. See the global INVOIC specification.
- UNS-segment is replaced by GEI-segment
- Party Consignee, NAD 3035, value CN is changed to Ship To, NAD 3035, value ST
- Contact details added for the Ship to Party: CTA-segment and COM-segment.
- LIN 1229 Code 3 is changed to code 38 for Replaced and code 4 is changed to 9 for Amendment
- IMD-segment is added. Volvo's article description.
- LOC 3055 added in both occurrences of LOC. Code 92.
- DTM 2005 in SG16. Value changes from 171 to 11.
- SCC-segment has been moved above the QTY-segment in segment group 18.
- DTM 2005 in SG19. Value changes from 2 to 10.
- New segment group, Authorization/Commitment (SG18). In this segment group we will give the commitment for raw material as a cumulated quantity, today given as code 3 attached to each required quantity for delivery.

VOLVO'S GLOBAL DELIVERY FORECAST MESSAGE
Implementation Guidelines
Branching Diagram of Used Segments and Segment Groups

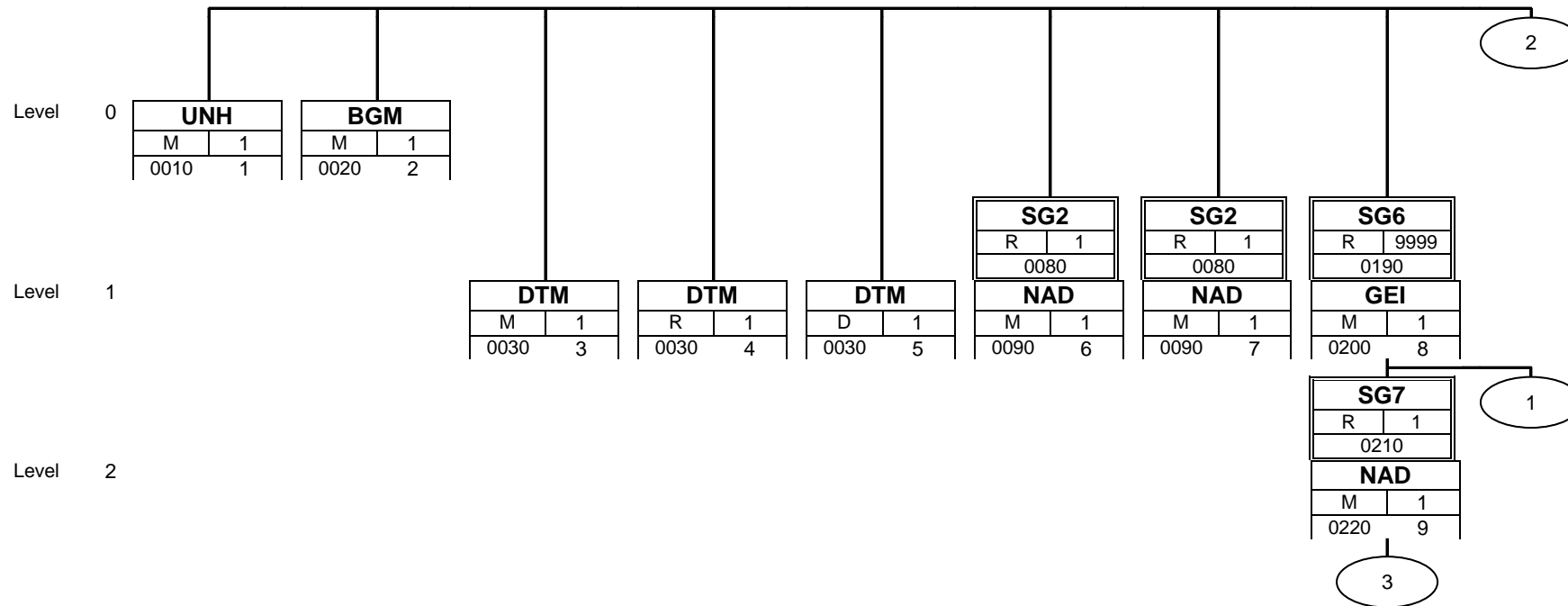

VOLVO'S GLOBAL DELIVERY FORECAST MESSAGE
 Implementation Guidelines
Branching Diagram of Used Segments and Segment Groups

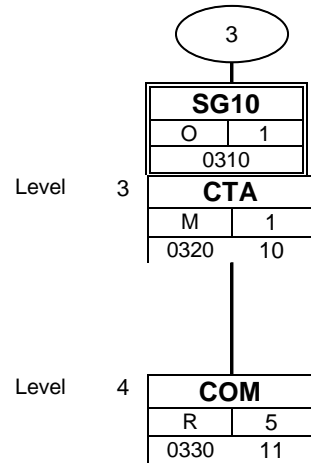

VOLVO'S GLOBAL DELIVERY FORECAST MESSAGE
Implementation Guidelines
Branching Diagram of Used Segments and Segment Groups

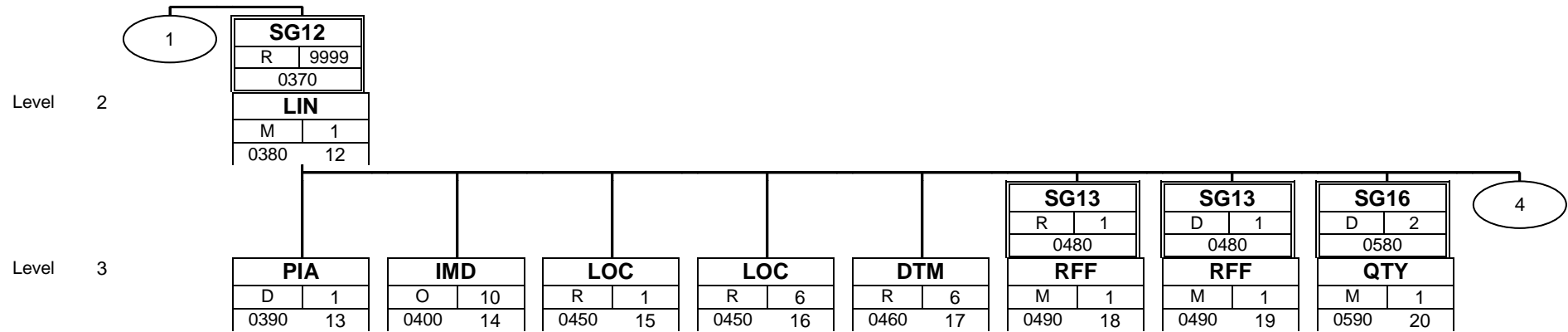

VOLVO'S GLOBAL DELIVERY FORECAST MESSAGE
 Implementation Guidelines
Branching Diagram of Used Segments and Segment Groups

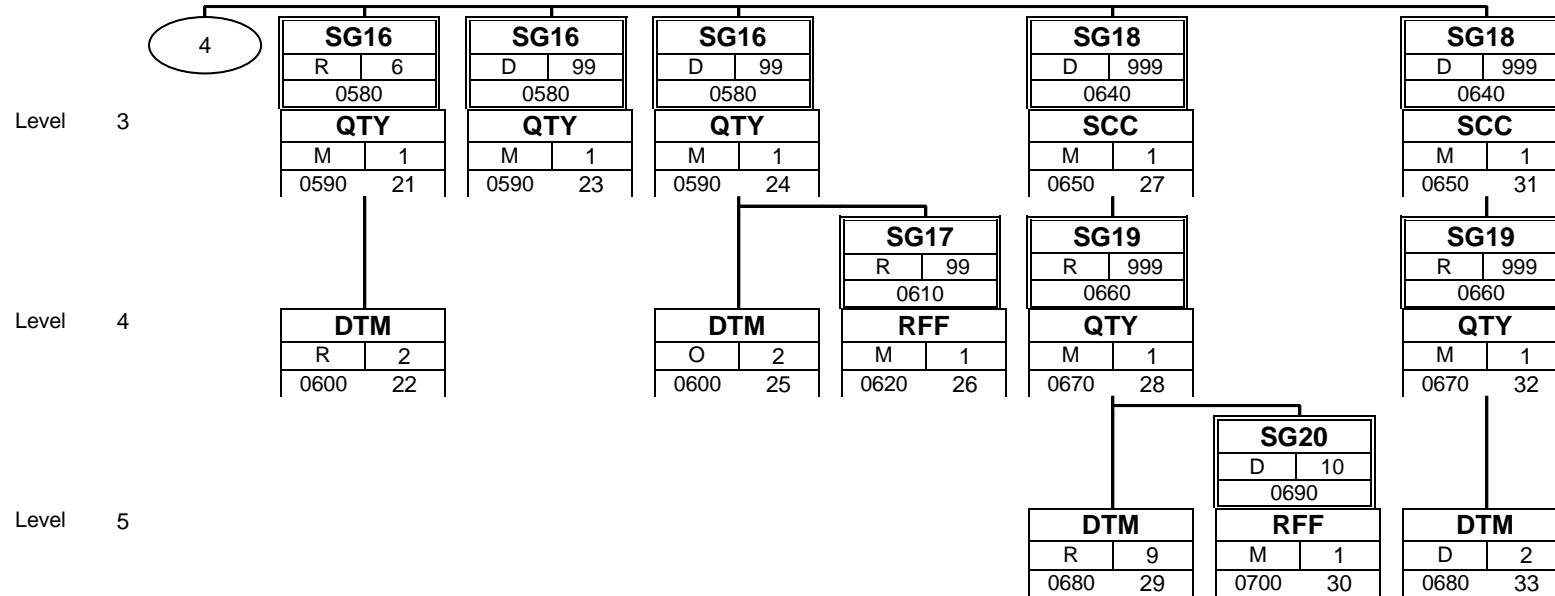

VOLVO'S GLOBAL DELIVERY FORECAST MESSAGE
Implementation Guidelines
Branching Diagram of Used Segments and Segment Groups

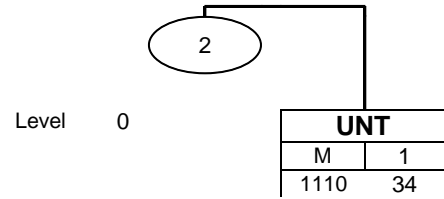

VOLVO'S GLOBAL DELIVERY FORECAST MESSAGE

UN/EDIFACT Message: Segment details

Segment: UNH
 Seq. No.: 1 Level: 0 Message header
 Status: M Max. Occ.: 1
 Counter: 0010

Name: Message header

Description of segment:

UN/EDIFACT			Implementation	
	Name	St Format	St Format	Use / Remarks
UNH				
0062	Message reference number	M an..14	M an..14	Message reference number should be unique for an agreed period of time. (Eg. Calendar year, model year)
S009	Message identifier	M	M	
0065	Message type	M an..6	M an..6	DELFOR = Delivery Forecast message
0052	Message version number	M an..3	M an..3	D = Draft version/UN/EDIFACT Directory
0054	Message release number	M an..3	M an..3	04A = Release 2004 - A
0051	Controlling agency	M an..2	M an..2	UN = UN/CEFACT
0057	Association assigned code	C an..6	R an..6	Identification of the subset release, assigned by the responsible organisation (Odette resp. joint automotive initiative). GMI051 - Global Delivery Forecast
0068	Common access reference	C an..35	N	not used
S010	Status of the transfer	C	N	not used
0070	Sequence of transfers	M n..2	N	not used
0073	First and last transfer	C a1	N	not used

Remark:

Example:

UNH+123456+DELFOR:D:04A:UN:GMI051'

VOLVO'S GLOBAL DELIVERY FORECAST MESSAGE

UN/EDIFACT Message: Segment details

Segment: BGM
 Seq. No.: 2 Level: 0 **Beginning of message**
 Status: M Max. Occ.: 1
 Counter: 0020

Name: Beginning of message

Description of segment:

UN/EDIFACT			Implementation	
	Name	St Format	St Format	Use / Remarks
BGM				
C002	Document/message name	C	R	
1001	Document name code	C an..3	R an..3	Code 236 - DELFOR message contains only forecasting figures Code 241 - DELFOR contains forecasting and firm figures (combination of firm instructions and forecasting figures) 236 = Delivery forecast 241 = Delivery schedule
1131	Code list identification code	C an..17	N	not used
3055	Code list responsible agency code	C an..3	N	not used
1000	Document name	C an..35	N	not used
C106	Document/message identification	C	R	
1004	Document identifier	C an..35	R an..35	Delivery Schedule Number.
1056	Version identifier	C an..9	N	not used
1060	Revision identifier	C an..6	N	not used
1225	Message function code	C an..3	N	not used
4343	Response type code	C an..3	N	not used

Remark:

Example:

BGM+241+201101170102'

VOLVO'S GLOBAL DELIVERY FORECAST MESSAGE

UN/EDIFACT Message: Segment details

Segment: DTM
 Seq. No.: 3 Level: 1 Date/time/period
 Status: M Max. Occ.: 1
 Counter: 0030

Name: Document Issue Date

Description of segment:

UN/EDIFACT			Implementation	
	Name	St Format	St Format	Use / Remarks
DTM				
C507	Date/time/period	M	M	
2005	Date or time or period function code qualifier	M an..3	M an..3	
2380	Date or time or period text	C an..35	R n8	137 = Document/message date/time Date, on which a document or business signal was issued.
2379	Date or time or period format code	C an..3	R an..3	102 = CCYMMDD

Remark:

Example:

DTM+137:20110117:102'

VOLVO'S GLOBAL DELIVERY FORECAST MESSAGE

UN/EDIFACT Message: Segment details

Segment: DTM
 Seq. No.: 4 Level: 1 Date/time/period
 Status: R Max. Occ.: 1
 Counter: 0030

Name: **Validity Start Date**

Description of segment:

UN/EDIFACT			Implementation	
	Name	St Format	St Format	Use / Remarks
DTM				
C507	Date/time/period	M	M	
2005	Date or time or period function code qualifier	M an..3	M an..3	
2380	Date or time or period text	C an..35	R n8	157 = Validity start date The date from when the new Delivery Schedule is valid.
2379	Date or time or period format code	C an..3	R an..3	
				102 = CCYMMDD

Remark:

Example:

DTM+157:20110117:102'

VOLVO'S GLOBAL DELIVERY FORECAST MESSAGE

UN/EDIFACT Message: Segment details

Segment: DTM
 Seq. No.: 5 Level: 1 Date/time/period
 Status: D Max. Occ.: 1
 Counter: 0030

Name: Expiry Date

Description of segment:

UN/EDIFACT			Implementation	
	Name	St Format	St Format	Use / Remarks
DTM				
C507	Date/time/period	M	M	
2005	Date or time or period function code qualifier	M an..3	M an..3	
2380	Date or time or period text	C an..35	R n8	36 = Expiry date The end date of the validity period for the new Delivery Schedule.
2379	Date or time or period format code	C an..3	R an..3	
				102 = CCYYMMDD

Remark:
Condition: This segment will only be used after special agreement.

Example:
DTM+36:20110131:102'

VOLVO'S GLOBAL DELIVERY FORECAST MESSAGE

UN/EDIFACT Message: Segment details

Group: SG2 Status: R Max. Occ.: 1 Buyer

Segment: NAD Seq. No.: 6 Level: 1 **Name and address**
 Status: M Max. Occ.: 1
 Counter: 0090

Name: Buyer's Name and Address

Description of segment:

UN/EDIFACT		Implementation		
	Name	St Format	St Format	Use / Remarks
NAD				
3035	Party function code qualifier	M an..3	M an..3	BY = Buyer
C082	Party identification details	C	R	
3039	Party identifier	M an..35	M an..35	Unique identification of a party by an ID.
1131	Code list identification code	C an..17	N	not used
3055	Code list responsible agency code	C an..3	R an..3	Code specifying the agency responsible for a code list.
				92 = Assigned by buyer or buyer's agent
C058	Name and address	C	N	not used
3124	Name and address description	M an..35	N	not used
3124	Name and address description	C an..35	N	not used
3124	Name and address description	C an..35	N	not used
3124	Name and address description	C an..35	N	not used
3124	Name and address description	C an..35	N	not used
C080	Party name	C	N	not used
3036	Party name	M an..35	N	not used
3036	Party name	C an..35	N	not used
3036	Party name	C an..35	N	not used
3036	Party name	C an..35	N	not used
3036	Party name	C an..35	N	not used
3045	Party name format code	C an..3	N	not used
C059	Street	C	N	not used
3042	Street and number or post office box identifier	M an..35	N	not used
3042	Street and number or post office box identifier	C an..35	N	not used
3042	Street and number or post office box identifier	C an..35	N	not used
3042	Street and number or post office box identifier	C an..35	N	not used
3164	City name	C an..35	N	not used
C819	Country sub-entity details	C	N	not used
3229	Country sub-entity name code	C an..9	N	not used
1131	Code list identification code	C an..17	N	not used
3055	Code list responsible agency code	C an..3	N	not used
3228	Country sub-entity name	C an..70	N	not used
3251	Postal identification code	C an..17	N	not used

VOLVO'S GLOBAL DELIVERY FORECAST MESSAGE

UN/EDIFACT Message: Segment details

UN/EDIFACT			Implementation	
	Name	St Format	St Format	Use / Remarks
3207	Country name code	C an..3	N	not used

Remark:

Volvo's identification of the buying company.

Example:

NAD+BY+4173:::92'

VOLVO'S GLOBAL DELIVERY FORECAST MESSAGE

UN/EDIFACT Message: Segment details

Group: **SG2** Status: R Max. Occ.: 1 Seller

Segment: **NAD** Seq. No.: 7 Level: 1 **Name and address**
 Status: M Max. Occ.: 1
 Counter: 0090

Name: Seller's Name and Address

Description of segment:

UN/EDIFACT		Implementation		
	Name	St Format	St Format	Use / Remarks
NAD				
3035	Party function code qualifier	M an..3	M an..3	SE = Seller
C082	Party identification details	C	R	
3039	Party identifier	M an..35	M an..35	Unique identification of a party by an ID. Must be given without leading zeroes.
1131	Code list identification code	C an..17	N	not used
3055	Code list responsible agency code	C an..3	R an..3	Code specifying the agency responsible for a code list.
				92 = Assigned by buyer or buyer's agent
C058	Name and address	C	N	not used
3124	Name and address description	M an..35	N	not used
3124	Name and address description	C an..35	N	not used
3124	Name and address description	C an..35	N	not used
3124	Name and address description	C an..35	N	not used
3124	Name and address description	C an..35	N	not used
C080	Party name	C	N	not used
3036	Party name	M an..35	N	not used
3036	Party name	C an..35	N	not used
3036	Party name	C an..35	N	not used
3036	Party name	C an..35	N	not used
3036	Party name	C an..35	N	not used
3045	Party name format code	C an..3	N	not used
C059	Street	C	N	not used
3042	Street and number or post office box identifier	M an..35	N	not used
3042	Street and number or post office box identifier	C an..35	N	not used
3042	Street and number or post office box identifier	C an..35	N	not used
3042	Street and number or post office box identifier	C an..35	N	not used
3164	City name	C an..35	N	not used
C819	Country sub-entity details	C	N	not used
3229	Country sub-entity name code	C an..9	N	not used
1131	Code list identification code	C an..17	N	not used
3055	Code list responsible agency code	C an..3	N	not used
3228	Country sub-entity name	C an..70	N	not used

VOLVO'S GLOBAL DELIVERY FORECAST MESSAGE

UN/EDIFACT Message: Segment details

UN/EDIFACT			Implementation	
	Name	St Format	St Format	Use / Remarks
3251	Postal identification code	C an..17	N	not used
3207	Country name code	C an..3	N	not used

Remark:

[Volvo's identification of the supplier.](#)

Seller: The party who has liability to fulfill the contract. It is often used in the sense of seller and supplier and ship-from.

In Europe and Japan seller is preferred to identify the selling and supplying party. Supplier is only included when the party actually differs from the seller.

Example:

NAD+SE+6128:::92'

VOLVO'S GLOBAL DELIVERY FORECAST MESSAGE

UN/EDIFACT Message: Segment details

Group: **SG6** Status: R Max. Occ.: 9999 Ship-to level (instruction line)

Segment: **GEI** Seq. No.: 8 Level: 1 **Processing information**
 Status: M Max. Occ.: 1
 Counter: 0200

Name: Processing information

Description of segment:

UN/EDIFACT		Implementation		
	Name	St Format	St Format	Use / Remarks
GEI				
9649	Processing information code qualifier	M an..3	M an..3	3 = Scheduling type information
C012	Processing indicator	C	N	not used
7365	Processing indicator description code	C an..3	N	not used
1131	Code list identification code	C an..17	N	not used
3055	Code list responsible agency code	C an..3	N	not used
7364	Processing indicator description	C an..35	N	not used
7187	Process type description code	C an..17	N	not used

Remark:

An instruction line gives the delivery instruction details (schedule dates, scheduled quantities etc.) for one individual ship-to party e.g. a plant in a delivery instruction or forecast.

Example:

GEI+3'

VOLVO'S GLOBAL DELIVERY FORECAST MESSAGE

UN/EDIFACT Message: Segment details

Group: **SG7** Status: R Max. Occ.: 1 Ship-to

Segment: **NAD** Seq. No.: 9 Level: 2 **Name and address**
 Status: M Max. Occ.: 1
 Counter: 0220

Name: **Ship-to**

Description of segment:

UN/EDIFACT		Implementation		
	Name	St Format	St Format	Use / Remarks
NAD				
3035	Party function code qualifier	M an..3	M an..3	ST = Ship to
C082	Party identification details	C	R	
3039	Party identifier	M an..35	M an..35	Unique identification of a party by an ID.
1131	Code list identification code	C an..17	N	not used
3055	Code list responsible agency code	C an..3	R an..3	Code specifying the agency responsible for a code list.
				92 = Assigned by buyer or buyer's agent
C058	Name and address	C	N	not used
3124	Name and address description	M an..35	N	not used
3124	Name and address description	C an..35	N	not used
3124	Name and address description	C an..35	N	not used
3124	Name and address description	C an..35	N	not used
3124	Name and address description	C an..35	N	not used
C080	Party name	C	D	Condition: Required when Transport labels are used.
3036	Party name	M an..35	M an..35	Single text line for specification of a name Shall be printed on the Transport label.
3036	Party name	C an..35	N	not used
3036	Party name	C an..35	N	not used
3036	Party name	C an..35	N	not used
3036	Party name	C an..35	N	not used
3045	Party name format code	C an..3	N	not used
C059	Street	C	O	Used by some Volvo group plants/warehouses only.
3042	Street and number or post office box identifier	M an..35	M an..35	The name that identifies the location of a house or building: usually within a street as part of an address.
3042	Street and number or post office box identifier	C an..35	N	not used
3042	Street and number or post office box identifier	C an..35	N	not used
3042	Street and number or post office box identifier	C an..35	N	not used
3164	City name	C an..35	O an..35	The name of the city, town, or village of this address. Used by some Volvo group plants/warehouses only.
C819	Country sub-entity details	C	O	Used by some Volvo group plants/warehouses only.
3229	Country sub-entity name code	C an..9	N	not used
1131	Code list identification code	C an..17	N	not used
3055	Code list responsible agency code	C an..3	N	not used

VOLVO'S GLOBAL DELIVERY FORECAST MESSAGE

UN/EDIFACT Message: Segment details

UN/EDIFACT			Implementation	
	Name	St Format	St Format	Use / Remarks
3228	Country sub-entity name	C an..70	O an..35	The name of the country sub-entity, state or similar. Used by some Volvo group plants/warehouses only.
3251	Postal identification code	C an..17	N	not used
3207	Country name code	C an..3	N	not used

Remark:

The party to which goods are to be shipped (consigned).

The Ship-to must be used, if there are multiple customer/buyer locations included in a DELFOR. In addition, in European business processes this ship-to party is often required even if it repeats the information given for the buyer already.

Volvo's plant identity

Example:

```
NAD+ST+4173:::92++VOLVO TRUCKS PARTS NORTH AMERICA CO+8288 GREEN MEADOWS DR+LEWIS  
CENTER+:::OH'
```

VOLVO'S GLOBAL DELIVERY FORECAST MESSAGE

UN/EDIFACT Message: Segment details

Group: **SG10** Status: O Max. Occ.: 1 Material Control Contact
 Used by some Volvo group plants/warehouses only.

Segment: **CTA** Seq. No.: 10 Level: 3 **Contact information**
 Status: M Max. Occ.: 1
 Counter: 0320

Name: **Material Control Contact**

Description of segment:

UN/EDIFACT			Implementation	
	Name	St Format	St Format	Use / Remarks
CTA				
3139	Contact function code	C an..3	R an..3	MC = Schedule contact
C056	Department or employee details	C	R	
3413	Department or employee name code	C an..17	N	not used
3412	Department or employee name	C an..35	R an..35	Name of the contact person or department

Remark:

Information that identifies the contact person or department material control or inspection matters, together with information about how they can be contacted.

One of the attributes of the contact has to be present.

Example:

CTA+MC+:JOE SMITH'

VOLVO'S GLOBAL DELIVERY FORECAST MESSAGE

UN/EDIFACT Message: Segment details

Group: **SG10** Status: O Max. Occ.: 1 Material Control Contact
 Used by some Volvo group plants/warehouses only.

Segment: **COM** Seq. No.: 11 Level: 4 **Communication contact**
 Status: R Max. Occ.: 5
 Counter: 0330

Name: **Communication contact**

Description of segment:

UN/EDIFACT			Implementation	
	Name	St Format	St Format	Use / Remarks
COM				
C076	Communication contact	M	M	
3148	Communication address identifier	M an..512	M an..100	The number of a telephone in a telecommunication system
3155	Communication address code qualifier	M an..3	M an..3	
				TE = Telephone

Remark:

Example:

COM+0123456789012:TE'

VOLVO'S GLOBAL DELIVERY FORECAST MESSAGE

UN/EDIFACT Message: Segment details

Group: **SG12** Status: R Max. Occ.: 9999 Scheduled Article Details

Segment: **LIN** Seq. No.: 12 Level: 2 **Line item**
 Status: M Max. Occ.: 1
 Counter: 0380

Name: **Line item**

Description of segment:

UN/EDIFACT		Implementation		
	Name	St Format	St Format	Use / Remarks
LIN				
1082	Line item identifier	C an..6	N	not used
1229	Action request/notification description code	C an..3	R an..3	<p>Code indicating action required as a result of the new instruction.</p> <p>Code 9 - Amendments - means the schedule lines of a previous forecast/ instruction are replaced only for the specific horizon indicated. All figures before and after remain valid. This requires an effective from and an effective to date on header level.</p> <p>Code 38 - the complete previous forecast / instruction for this line item is replaced by new figures for the full horizon.</p> <p>It is business practice to use at least one time a zero quantity schedule line for articles that have been part of previous schedules but are now no longer part of the schedule in the case of the 'complete replacement' situation.</p> <p>9 = Amendments 38 = Replaced</p>
C212	Item number identification	C	R	<p>Article ID(s) as assigned by one or more of the involved parties.</p>
7140	Item identifier	C an..35	R an..35	<p>Information directly relating to the identification of an article by the buyer's identification system.</p> <p>Note: The term article is synonym with the term item. Since in Odette and in the global joint automotive projects the term article has been used, this naming convention has been continued.</p> <p>Volvo's Article number.</p>
7143	Item type identification code	C an..3	R an..3	<p>IN = Buyer's item number</p>
1131	Code list identification code	C an..17	N	not used
3055	Code list responsible agency code	C an..3	N	not used
C829	Sub-line information	C	N	not used
5495	Sub-line indicator code	C an..3	N	not used
1082	Line item identifier	C an..6	N	not used
1222	Configuration level number	C n..2	N	not used
7083	Configuration operation code	C an..3	N	not used

Remark:

A product required by the buyer, which is scheduled to be delivered

All segments in the detail section following the LIN segment refer to the line item.

The supplier is responsible for converting Volvo's article number into the supplier's own internal number.

VOLVO'S GLOBAL DELIVERY FORECAST MESSAGE

UN/EDIFACT Message: Segment details

Example:

LIN++38+1137005:IN'

VOLVO'S GLOBAL DELIVERY FORECAST MESSAGE

UN/EDIFACT Message: Segment details

Group: **SG12** Status: R Max. Occ.: 9999 Scheduled Article Details

Segment: **PIA** Seq. No.: 13 Level: 3 **Additional product id**
 Status: D Max. Occ.: 1
 Counter: 0390

Name: **Additional product id**

Description of segment:

UN/EDIFACT		Implementation		
	Name	St Format	St Format	Use / Remarks
PIA				
4347	Product identifier code qualifier	M an..3	M an..3	1 = Additional identification
C212	Item number identification	M	M	
7140	Item identifier	C an..35	R an..35	Vendor item number. Used by some Volvo group plants/warehouses only OR The number of a technical drawing allocated to an item.
7143	Item type identification code	C an..3	R an..3	VN = Vendor item number OR DR = Drawing revision number
1131	Code list identification code	C an..17	N	not used
3055	Code list responsible agency code	C an..3	N	not used
C212	Item number identification	C	C	not used
7140	Item identifier	C an..35	R an..35	Vendor item number. Used by some Volvo group plants/warehouses only OR The number of a technical drawing allocated to an item.
7143	Item type identification code	C an..3	R an..3	VN = Vendor item number OR DR = Drawing revision number
1131	Code list identification code	C an..17	N	not used
3055	Code list responsible agency code	C an..3	N	not used
C212	Item number identification	C	N	not used
7140	Item identifier	C an..35	N	not used
7143	Item type identification code	C an..3	N	not used
1131	Code list identification code	C an..17	N	not used
3055	Code list responsible agency code	C an..3	N	not used
C212	Item number identification	C	N	not used
7140	Item identifier	C an..35	N	not used
7143	Item type identification code	C an..3	N	not used
1131	Code list identification code	C an..17	N	not used
3055	Code list responsible agency code	C an..3	N	not used
C212	Item number identification	C	N	not used
7140	Item identifier	C an..35	N	not used
7143	Item type identification code	C an..3	N	not used
1131	Code list identification code	C an..17	N	not used

VOLVO'S GLOBAL DELIVERY FORECAST MESSAGE

UN/EDIFACT Message: Segment details

UN/EDIFACT			Implementation	
	Name	St Format	St Format	Use / Remarks
3055	Code list responsible agency code	C an..3	N	not used

Remark: A class containing several technical status properties in addition to those that may be derived from the article number itself.

Condition: Drawing revision number will only be used after special agreement. Vendor number will be sent by some Volvo plants for some suppliers only.

Example: PIA+1+P04:DR'
PIA+1+ABCD1234:VN'
PIA+1+ABCD1234:VN+P04:DR'

VOLVO'S GLOBAL DELIVERY FORECAST MESSAGE

UN/EDIFACT Message: Segment details

Group: **SG12** Status: R Max. Occ.: 9999 Scheduled Article Details

Segment: **IMD** Seq. No.: 14 Level: 3 **Item description**
 Status: O Max. Occ.: 10
 Counter: 0400

Used by some Volvo group plants/warehouses only.

Name: **Item description**

Description of segment:

UN/EDIFACT			Implementation	
	Name	St Format	St Format	Use / Remarks
IMD				
7077	Description format code	C an..3	N	not used
C272	Item characteristic	C	N	not used
7081	Item characteristic code	C an..3	N	not used
1131	Code list identification code	C an..17	N	not used
3055	Code list responsible agency code	C an..3	N	not used
C273	Item description	C	R	
7009	Item description code	C an..17	N	not used
1131	Code list identification code	C an..17	N	not used
3055	Code list responsible agency code	C an..3	N	not used
7008	Item description	C an..256	R an..35	Volvo's article description
7008	Item description	C an..256	N	not used
3453	Language name code	C an..3	N	not used
7383	Surface or layer code	C an..3	N	not used

Remark:

Article's (short) description in plain text
 Used by some Volvo group plants/warehouses only.

Example:

IMD+++:::BOLT'

VOLVO'S GLOBAL DELIVERY FORECAST MESSAGE

UN/EDIFACT Message: Segment details

Group: **SG12** Status: R Max. Occ.: 9999 Scheduled Article Details

Segment: **LOC** Seq. No.: 15 Level: 3 **Place/location identification**
 Status: R Max. Occ.: 1
 Counter: 0450

Name: **Place of discharge**

Description of segment:

UN/EDIFACT		Implementation		
	Name	St Format	St Format	Use / Remarks
LOC				
3227	Location function code qualifier	M an..3	M an..3	11 = Place/port of discharge
C517	Location identification	C	R	
3225	Location name code	C an..35	R an..35	Identifier / code specifying the name of a location. Volvo's identity on the place of discharge. Shall not be stated on the transport label.
1131	Code list identification code	C an..17	N	not used
3055	Code list responsible agency code	C an..3	R an..3	Code specifying the agency responsible for a code list.
				92 = Assigned by buyer or buyer's agent
3224	Location name	C an..256	N	not used
C519	Related location one identification	C	N	not used
3223	First related location name code	C an..25	N	not used
1131	Code list identification code	C an..17	N	not used
3055	Code list responsible agency code	C an..3	N	not used
3222	First related location name	C an..70	N	not used
C553	Related location two identification	C	N	not used
3233	Second related location name code	C an..25	N	not used
1131	Code list identification code	C an..17	N	not used
3055	Code list responsible agency code	C an..3	N	not used
3232	Second related location name	C an..70	N	not used
5479	Relation code	C an..3	N	not used

Remark:

Example:

LOC+11+556:::92'

VOLVO'S GLOBAL DELIVERY FORECAST MESSAGE

UN/EDIFACT Message: Segment details

Group: **SG12** Status: R Max. Occ.: 9999 Scheduled Article Details

Segment: **LOC** Seq. No.: 16 Level: 3 **Place/location identification**
 Status: R Max. Occ.: 6
 Counter: 0450

Name: **Internal place of destination**

Description of segment:

UN/EDIFACT		Implementation		
	Name	St Format	St Format	Use / Remarks
LOC				
3227	Location function code qualifier	M an..3	M an..3	159 = Additional internal destination
C517	Location identification	C	R	
3225	Location name code	C an..35	R an..35	Identifier / code specifying the name of a location. Final unloading point. To be printed on the transport label in the field "Dock and Gate".
1131	Code list identification code	C an..17	N	not used
3055	Code list responsible agency code	C an..3	R an..3	Code specifying the agency responsible for a code list. 92 = Assigned by buyer or buyer's agent
3224	Location name	C an..256	N	not used
C519	Related location one identification	C	N	not used
3223	First related location name code	C an..25	N	not used
1131	Code list identification code	C an..17	N	not used
3055	Code list responsible agency code	C an..3	N	not used
3222	First related location name	C an..70	N	not used
C553	Related location two identification	C	N	not used
3233	Second related location name code	C an..25	N	not used
1131	Code list identification code	C an..17	N	not used
3055	Code list responsible agency code	C an..3	N	not used
3232	Second related location name	C an..70	N	not used
5479	Relation code	C an..3	N	not used

Remark:

An internal location within the ship-to's premises, where goods are moved to after they have been unloaded, e.g. an assembly line, an internal warehouse, etc.

Example:

LOC+159+F-11 556::92'

VOLVO'S GLOBAL DELIVERY FORECAST MESSAGE

UN/EDIFACT Message: Segment details

Group: **SG12** Status: R Max. Occ.: 9999 Scheduled Article Details

Segment: **DTM** Seq. No.: 17 Level: 3 **Date/time/period**
 Status: R Max. Occ.: 6
 Counter: 0460

Name: **Date/time/period**

Description of segment:

UN/EDIFACT		Implementation		
	Name	St Format	St Format	Use / Remarks
DTM				
C507	Date/time/period	M	M	
2005	Date or time or period function code qualifier	M an..3	M an..3	
2380	Date or time or period text	C an..35	R n8	257 = Calculation date/time/period Date and time on which the delivery quantities are calculated.
2379	Date or time or period format code	C an..3	R an..3	
				102 = CCYMMDD

Remark:

Example:

DTM+257:20110117:102'

VOLVO'S GLOBAL DELIVERY FORECAST MESSAGE

UN/EDIFACT Message: Segment details

Group: SG13 Status: R Max. Occ.: 1 Order reference

Segment: RFF Seq. No.: 18 Level: 3 **Reference**
 Status: M Max. Occ.: 1
 Counter: 0490

Name: **Order reference**

Description of segment:

UN/EDIFACT			Implementation	
	Name	St Format	St Format	Use / Remarks
RFF				
C506	Reference	M	M	
1153	Reference code qualifier	M an..3	M an..3	
1154	Reference identifier	C an..70	R an..17	ON = Buyers order number Volvo's Purchase order number.
1156	Document line identifier	C an..6	D an..6	Sequential number generated by Volvo to identify a line item in the order. Condition: This data element will only be used after special agreement.
4000	Reference version identifier	C an..35	N	not used
1060	Revision identifier	C an..6	N	not used

Remark:

[Reference to a Purchase order.](#)

Example:

RFF+ON:M591079556'

VOLVO'S GLOBAL DELIVERY FORECAST MESSAGE

UN/EDIFACT Message: Segment details

Group: **SG13** Status: D Max. Occ.: 1 Reference to Previous Delivery Instruction
 Condition: This segment group will not be given in the first delivery schedule.

Segment: **RFF** Seq. No.: 19 Level: 3 **Reference**
 Status: M Max. Occ.: 1
 Counter: 0490

Name: **Previous Delivery Instruction**

Description of segment:

UN/EDIFACT			Implementation	
	Name	St Format	St Format	Use / Remarks
RFF				
C506	Reference	M	M	
1153	Reference code qualifier	M an..3	M an..3	
1154	Reference identifier	C an..70	R an..17	AIF = Previous delivery instruction number Previous Delivery Instruction number.
1156	Document line identifier	C an..6	N	not used
4000	Reference version identifier	C an..35	N	not used
1060	Revision identifier	C an..6	N	not used

Example:

RFF+AIF:201101120210'

VOLVO'S GLOBAL DELIVERY FORECAST MESSAGE

UN/EDIFACT Message: Segment details

Group: **SG16** Status: D Max. Occ.: 2 Delivery balance
 Condition: This segment group will be omitted when no Backorder quantity exists.

Segment: **QTY** Seq. No.: 20 Level: 3 **Quantity**
 Status: M Max. Occ.: 1
 Counter: 0590

Name: **Delivery balance quantity**

Description of segment:

UN/EDIFACT			Implementation	
	Name	St Format	St Format	Use / Remarks
QTY				
C186	Quantity details	M	M	
6063	Quantity type code qualifier	M an..3	M an..3	
6060	Quantity	M an..35	M n..15	83 = Backorder quantity Quantity that is not received at Ship To. Can include quantity in transit.
6411	Measurement unit code	C an..8	D an..8	Code specifying the unit of measurement. Recommend use UN/ECE recommendation 20, Common code. Condition: Default value is C62.

Remark:

Example:

QTY+83:5000'

VOLVO'S GLOBAL DELIVERY FORECAST MESSAGE

UN/EDIFACT Message: Segment details

Group: **SG16** Status: R Max. Occ.: 6 Cumulative quantities

Accumulated quantities concerning the article.

Segment: **QTY** Seq. No.: 21 Level: 3 **Quantity**
 Status: M Max. Occ.: 1
 Counter: 0590

Name: **Cumulative quantities**

Description of segment:

UN/EDIFACT			Implementation	
	Name	St Format	St Format	Use / Remarks
QTY				
C186	Quantity details	M	M	
6063	Quantity type code qualifier	M an..3	M an..3	
6060	Quantity	M an..35	M n..15	70 = Cumulative quantity received Cumulated received quantity since the date given in DTM-segment, qualifier 51. If no deliveries received, zero will be given.
6411	Measurement unit code	C an..8	D an..8	Code specifying the unit of measurement Recommend use UN/ECE Recommendation 20, Common code. Condition: Default value is C62.

Remark:

Example:

QTY+70:2300'

VOLVO'S GLOBAL DELIVERY FORECAST MESSAGE

UN/EDIFACT Message: Segment details

Group: **SG16** Status: R Max. Occ.: 6 Cumulative quantities
 Accumulated quantities concerning the article.

Segment: **DTM** Seq. No.: 22 Level: 4 **Date/time/period**
 Status: R Max. Occ.: 2
 Counter: 0600

Name: Cumulative quantity date(s)

Description of segment:

UN/EDIFACT			Implementation	
	Name	St Format	St Format	Use / Remarks
DTM				
C507	Date/time/period	M	M	
2005	Date or time or period function code qualifier	M an..3	M an..3	
2380	Date or time or period text	C an..35	R n8	51 = Cumulative quantity start date Start date of a given period
2379	Date or time or period format code	C an..3	R an..3	
				102 = CCYYMMDD

Remark:

Example:

DTM+51:20110101:102'

VOLVO'S GLOBAL DELIVERY FORECAST MESSAGE

UN/EDIFACT Message: Segment details

Group: **SG16** Status: D Max. Occ.: 99 Received quantities
 Condition: This segment group will be omitted if no despatch is received.

Segment: **QTY** Seq. No.: 23 Level: 3 **Quantity**
 Status: M Max. Occ.: 1
 Counter: 0590

Name: **Received quantities**

Description of segment:

UN/EDIFACT			Implementation	
	Name	St Format	St Format	Use / Remarks
QTY				
C186	Quantity details	M	M	
6063	Quantity type code qualifier	M an..3	M an..3	
6060	Quantity	M an..35	M n..15	48 = Received quantity The quantity received by the ship-to party.
6411	Measurement unit code	C an..8	D an..8	Code specifying the unit of measurement Condition: Default value is C62.

Remark:

[The quantity which has been received by the ship-to](#)

This quantity is needed when the quantity received by the ship-to is different from the quantity given in the despatch note.

Example:

QTY+48:500'

VOLVO'S GLOBAL DELIVERY FORECAST MESSAGE

UN/EDIFACT Message: Segment details

Group: **SG16** Status: D Max. Occ.: 99 Despatched quantities and dates.
 Condition: This segment group will be omitted if no despatch is received.

Segment: **QTY** Seq. No.: 24 Level: 3 **Quantity**
 Status: M Max. Occ.: 1
 Counter: 0590

Name: **Despatched quantities**

Description of segment:

UN/EDIFACT			Implementation	
	Name	St Format	St Format	Use / Remarks
QTY				
C186	Quantity details	M	M	
6063	Quantity type code qualifier	M an..3	M an..3	
6060	Quantity	M an..35	M n..15	12 = Despatch quantity Despatched Quantity Value
6411	Measurement unit code	C an..8	D an..8	Code specifying the unit of measurement Recommend use UN/ECE Recommendation 20, Common code. Condition: Default value is C62.

Remark:
[Actual quantity despatched and shipped by the seller/ ship from.](#)

Example:
 QTY+12:500'

VOLVO'S GLOBAL DELIVERY FORECAST MESSAGE

UN/EDIFACT Message: Segment details

Group: **SG16** Status: D Max. Occ.: 99 Despatched quantities and dates.
 Condition: This segment group will be omitted if no despatch is received.

Segment: **DTM** Seq. No.: 25 Level: 4 **Date/time/period**
 Status: D Max. Occ.: 2
 Counter: 0600

Name: **Despatch date**

Description of segment:

UN/EDIFACT			Implementation	
	Name	St Format	St Format	Use / Remarks
DTM				
C507	Date/time/period	M	M	
2005	Date or time or period function code qualifier	M an..3	M an..3	
2380	Date or time or period text	C an..35	R n8	11 = Despatch date and or time Date/time on which the goods are or are expected to be despatched or shipped.
2379	Date or time or period format code	C an..3	R an..3	
				102 = CCYYMMDD

Remark:

Example:

DTM+11:20110108:102'

VOLVO'S GLOBAL DELIVERY FORECAST MESSAGE

UN/EDIFACT Message: Segment details

Group: **SG17** Status: R Max. Occ.: 99 Despatch / receiving document reference

Segment: **RFF** Seq. No.: 26 Level: 4 **Reference**
 Status: M Max. Occ.: 1
 Counter: 0620

Name: Reference

Description of segment:

UN/EDIFACT			Implementation	
	Name	St Format	St Format	Use / Remarks
RFF				
C506	Reference	M	M	
1153	Reference code qualifier	M an..3	M an..3	AAK = Despatch advice number
1154	Reference identifier	C an..70	R an..17	Unique identifier of a document. Synonym: document number
1156	Document line identifier	C an..6	N	not used
4000	Reference version identifier	C an..35	N	not used
1060	Revision identifier	C an..6	N	not used

Remark:

Reference identifier assigned by the issuer to the document for a despatch advice

Example:

RFF+AAK:12785'

VOLVO'S GLOBAL DELIVERY FORECAST MESSAGE

UN/EDIFACT Message: Segment details

Group: **SG18** Status: D Max. Occ.: 999 Scheduling data

Information providing dates/times/periods of deliveries, quantity, and additional references valid for the item.

Delivery Date and Delivery Period shall be used mutually exclusive.

Segment: **SCC** Seq. No.: 27 Level: 3 **Scheduling conditions**
 Status: M Max. Occ.: 1
 Counter: 0650

Name: **Scheduling conditions**

Description of segment:

UN/EDIFACT			Implementation	
	Name	St Format	St Format	Use / Remarks
SCC				
4017	Delivery plan commitment level code	M an..3	M an..3	Code indicating the level of commitment of a delivery instruction. 1 = Firm 4 = Planning/forecast 24 = Reference to commercial agreement between partners
4493	Delivery instruction code	C an..3	N	not used
C329	Pattern description	C	N	not used
2013	Frequency code	C an..3	N	not used
2015	Despatch pattern code	C an..3	N	not used
2017	Despatch pattern timing code	C an..3	N	not used

Remark:

Example:

SCC+1'

VOLVO'S GLOBAL DELIVERY FORECAST MESSAGE

UN/EDIFACT Message: Segment details

Group: **SG19** Status: R Max. Occ.: 999 Scheduled quantity

Segment: **QTY** Seq. No.: 28 Level: 4 **Quantity**
 Status: M Max. Occ.: 1
 Counter: 0670

Name: **Quantity**

Description of segment:

UN/EDIFACT			Implementation	
	Name	St Format	St Format	Use / Remarks
QTY				
C186	Quantity details	M	M	
6063	Quantity type code qualifier	M an..3	M an..3	Code identifying the reason of the delivery instruction.
6060	Quantity	M an..35	M n..15	113 = Quantity to be delivered (default delivery qty) Quantity scheduled by the buyer (material release issuer) to be delivered at a specified point in time or within a period. It is business practice to use at least one time a zero quantity schedule line for articles that have been part of previous schedules but are now no longer part of the schedule in the case of the 'complete replacement' situation.
6411	Measurement unit code	C an..8	D an..8	Code specifying the unit of measurement Recommend use UN/ECE Recommendation 20, Common code. Condition: Default value is C62.

Remark:

Quantity scheduled by the buyer (material release issuer) to be delivered at a specified point in time or within a period.

Example:

QTY+113:4500'

VOLVO'S GLOBAL DELIVERY FORECAST MESSAGE

UN/EDIFACT Message: Segment details

Group: **SG19** Status: R Max. Occ.: 999 Scheduled quantity

Segment: **DTM** Seq. No.: 29 Level: 5 **Date/time/period**
 Status: R Max. Occ.: 9
 Counter: 0680

Name: **Scheduled dates**

Description of segment:

UN/EDIFACT		Implementation		
	Name	St Format	St Format	Use / Remarks
DTM				
C507	Date/time/period	M	M	
2005	Date or time or period function code qualifier	M an..3	R an..3	Code 10 - shipment date/time of departure, fixed Code 63 - shipment (delivery initiated) date/time of departure, latest Code 64 - shipment (delivery initiated) date/time of departure, earliest 10 = Shipment date/time, requested 63 = Delivery date/time, latest 64 = Delivery date/time, earliest
2380	Date or time or period text	C an..35	R n..12	Date of delivery
2379	Date or time or period format code	C an..3	D an..3	The qualifier 203 will only be used when there are more than one requirement in a day. 102 = CCYMMDD 203 = CCYMMDDHHMM

Remark:

Example:

DTM+10:20110203:102'

VOLVO'S GLOBAL DELIVERY FORECAST MESSAGE

UN/EDIFACT Message: Segment details

Group: **SG20** Status: D Max. Occ.: 10 Reference documents
 Condition: After special agreement with Volvo, a reference is made here to an order line or other customer oriented reference concept.

Segment: **RFF** Seq. No.: 30 Level: 5 **Reference**
 Status: M Max. Occ.: 1
 Counter: 0700

Name: **Reference**

Description of segment:

UN/EDIFACT			Implementation	
	Name	St Format	St Format	Use / Remarks
RFF				
C506	Reference	M	M	
1153	Reference code qualifier	M an..3	M an..3	
1154	Reference identifier	C an..70	R an..17	AAP = Part consignment number Reference to a specific consignment forming part of a contract allowing part deliveries.
1156	Document line identifier	C an..6	N	not used
4000	Reference version identifier	C an..35	N	not used
1060	Revision identifier	C an..6	N	not used

Remark:

Example:

RFF+AAP:36001'

VOLVO'S GLOBAL DELIVERY FORECAST MESSAGE

UN/EDIFACT Message: Segment details

Group: **SG18** Status: D Max. Occ.: 999 Authorization / Commitment

Class providing the level of commitment of the buyer, per type of commitment.

The authorisation may be given: -

- as a discrete quantity
- for a period in terms of start and end date
- for a period in terms of number of periods

Condition: To be given when applicable.

Segment: **SCC** Seq. No.: 31 Level: 3 **Scheduling conditions**
 Status: M Max. Occ.: 1
 Counter: 0650

Name: Scheduling conditions

Description of segment:

UN/EDIFACT			Implementation	
	Name	St Format	St Format	Use / Remarks
SCC				
4017	Delivery plan commitment level code	M an..3	M an..3	Code indicating the buyer's level of commitment for the cumulative quantities scheduled. 3 = Commitment for material
4493	Delivery instruction code	C an..3	N	not used
C329	Pattern description	C	N	not used
2013	Frequency code	C an..3	N	not used
2015	Despatch pattern code	C an..3	N	not used
2017	Despatch pattern timing code	C an..3	N	not used

Remark:

Example:

SCC+3'

VOLVO'S GLOBAL DELIVERY FORECAST MESSAGE

UN/EDIFACT Message: Segment details

Group: **SG19** Status: R Max. Occ.: 999 Date(s) and quantities

Segment: **QTY** Seq. No.: 32 Level: 4 **Quantity**
 Status: M Max. Occ.: 1
 Counter: 0670

Name: **Quantity**

Description of segment:

UN/EDIFACT			Implementation	
	Name	St Format	St Format	Use / Remarks
QTY				
C186	Quantity details	M	M	
6063	Quantity type code qualifier	M an..3	M an..3	
6060	Quantity	M an..35	M n..15	1 = Discrete quantity Discrete quantity of materials or finished goods authorised to be produced or purchased to meet the expected requirements of the buyer as committed in a forecast or schedule.
6411	Measurement unit code	C an..8	D an..8	Code specifying the unit of measurement Recommend use UN/ECE Recommendation 20, Common code. Condition: Default value is C62.

Remark:

Example:

QTY+1:14500'

VOLVO'S GLOBAL DELIVERY FORECAST MESSAGE

UN/EDIFACT Message: Segment details

Group: **SG19** Status: R Max. Occ.: 999 Date(s) and quantities

Segment: **DTM** Seq. No.: 33 Level: 5 **Date/time/period**
 Status: D Max. Occ.: 2
 Counter: 0680

Name: Authorisation period

Description of segment:

UN/EDIFACT			Implementation	
	Name	St Format	St Format	Use / Remarks
DTM				
C507	Date/time/period	M	M	
2005	Date or time or period function code qualifier	M an..3	M an..3	194 = Start date/time 206 = End date/time
2380	Date or time or period text	C an..35	R n8	Date defining the validity of figures given in an occurrence of the entity Production Authorization.
2379	Date or time or period format code	C an..3	R an..3	
				102 = CCYMMDD

Remark:

Condition: To be given when applicable

Example:

DTM+194:20110210:102'

VOLVO'S GLOBAL DELIVERY FORECAST MESSAGE

UN/EDIFACT Message: Segment details

Segment:

UNT

Seq. No.: 34 Level: 0
Status: M Max. Occ.: 1
Counter: 1110

Message trailer

Name: Message trailer

Description of segment:

UN/EDIFACT		Implementation		
	Name	St Format	St Format	Use / Remarks
UNT				
0074	Number of segments in the message	M n..6	M n..6	
0062	Message reference number	M an..14	M an..14	

Remark:

Example:

UNT+125+123456'

VOLVO'S GLOBAL DELIVERY FORECAST MESSAGE

Implementation Guidelines

Example

Example:

UNH+123456+DELFOR:D:04A:UN:GMI051	Message header
BGM+241+201101170102'	Delivery schedule number
DTM+137:20110117:102'	Issue date
DTM+157:20110117:102'	Effective from
NAD+BY+1020::92'	Legal Buyer
NAD+SE+6128::92'	Seller
GEI+3'	Section separator
NAD+ST+1001::92++TUVE'	Ship to
LIN++38+1137005:IN'	Buyer's Article number
PIA+1+P04:DR'	Drawing information
LOC+11+020'	Place of discharge
LOC+159+F-11 020'	Final delivery point
DTM+257:20110117:102'	Calculation date
RFF+ON:371906128020'	Purchase Order Number
RFF+AIF:201101120210'	Previous delivery schedule number
QTY+83:500'	Quantity in Backorder
QTY+70:23000'	Cumulative quantity received
DTM+51:20110101:102'	Accumulation start date
QTY+12:500'	Delivered quantity (according to DESADV)
QTY+48:500'	Received quantity
DTM+11:20110108:102'	Date of despatch
RFF+AAK:12785'	Despatch advice number
QTY+12:500'	Delivered quantity (according to DESADV)
QTY+48:500'	Received quantity
DTM+11:20110105:102'	Date of despatch
RFF+AAK:12760'	Despatch advice number
QTY+12:500'	Delivered quantity (according to DESADV)
QTY+48:500'	Received quantity
DTM+11:20110102:102'	Date of despatch
RFF+AAK:12725'	Despatch advice number
SCC+1'	Firm
QTY+113:500'	Quantity to be delivered
DTM+10:20110203:102'	Date of despatch
SCC+1'	Firm
QTY+113:500'	Quantity to be delivered
DTM+10:20110210:102'	Date of despatch
SCC+1'	Firm
QTY+113:500'	Quantity to be delivered
DTM+10:20110217:102'	Date of despatch
SCC+4'	Forecast
QTY+113:500'	Quantity to be delivered
DTM+10:20110225:102'	Date of despatch
SCC+4'	Forecast
QTY+113:500'	Quantity to be delivered
DTM+10:20110304:102'	Date of despatch

VOLVO'S GLOBAL DELIVERY FORECAST MESSAGE

Implementation Guidelines

Example

SCC+4'	Forecast
QTY+113:500'	Quantity to be delivered
DTM+10:20110311:102'	Date of despatch
SCC+4'	Forecast
QTY+113:500'	Quantity to be delivered
DTM+10:20110318:102'	Date of despatch
SCC+4'	Forecast
QTY+113:500'	Quantity to be delivered
DTM+10:20110325:102'	Date of despatch
SCC+3'	Commitment for material
QTY+1:2000'	Committed quantity for material
DTM+194:20110210:102'	Start date
DTM+206:20110302:102'	End date
UNT+59+123456'	Message trailer